

Excellence in seaming

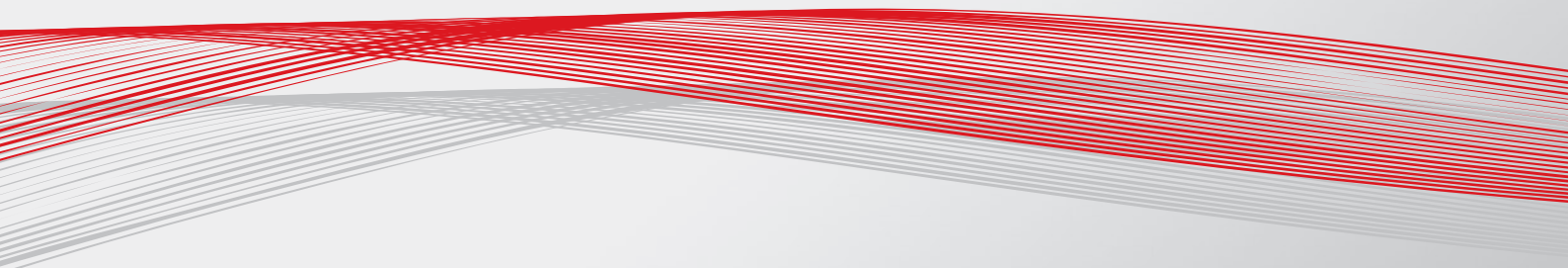

**3588**

Programmable automatic pocket setter

---

Freely programmable automatic sewing unit for sewing pockets on jeans, shirts, blouses, work-wear and similar articles. Pockets are not only functional, but also an important part of fashion, since they are very prominent on garments perfect workmanship is imperative. This is especially true, when functionality is combined with decoration.



### **PFAFF 3588-12/021 and PFAFF 3588-22/021**

- For shirts, blouses and similar articles
- For attaching un-folded pockets
- Sewing areas: subclass -12/021: 250 x 250 mm  
subclass -22/021: 280 x 280 mm

### **PFAFF 3588-16/031 (new)**

- For shirts, blouses and light jeans fabrics
- With zigzag machine head
- Sewing area: 250 x 250 mm (280 x 280 mm on request)



### **PFAFF 3588-05/020 and PFAFF 3588-15/020**

- For jeans, working wear and similar articles
- For processing pre-folded and un-folded pockets (in combination)
- Sewing of cotton and synthetic threads up to 11/3
- Sewing areas: subclass -05/020: 250 x 250 mm  
subclass -15/020: 280 x 280 mm

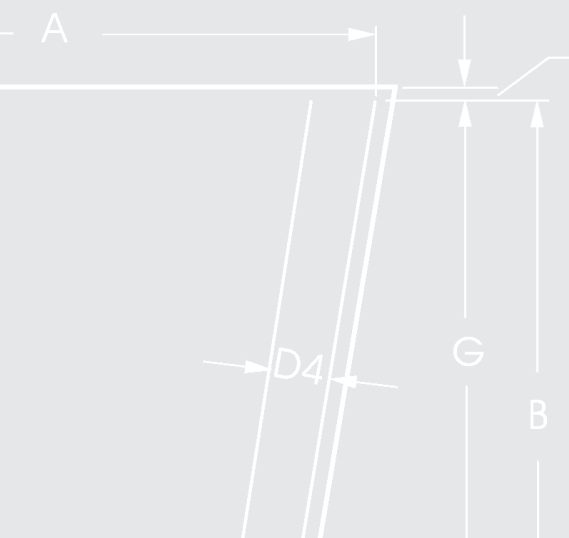

*„Best possible ergonomics,  
highest productivity and exceptional operating  
comfort characterizes this automated machine“*

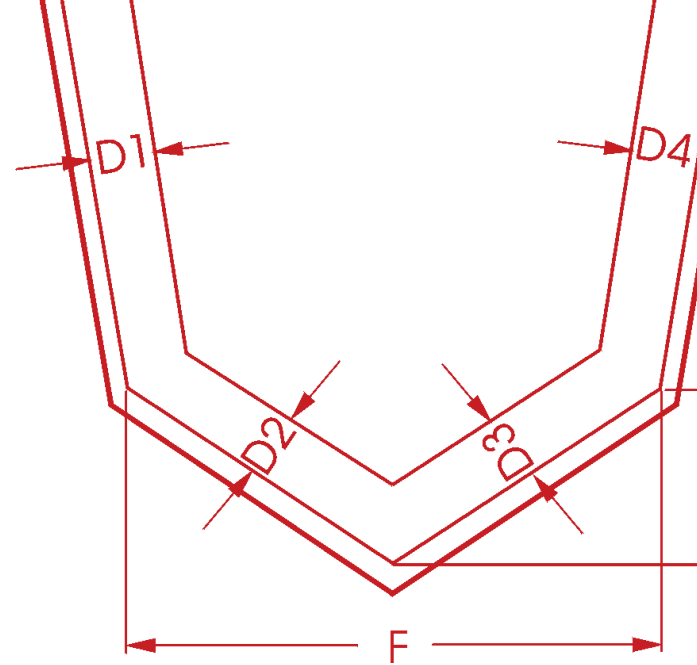

### Features and advantages:

- The intermittent material feed reduces hook wear to a minimum and allows stitch lengths of 8 mm
- Individual seam programming and exact seam correction for different materials guarantee a highly sewing reliability and consistent quality
- Efficient combination of two operations with optional style kits to set pockets and attach flaps in one operation or insert labels
- Superior sewing results even if setting pockets with radii < 20 mm
- Individually designing and programming of decorative seams
- Easy loading and positioning of work piece due to a 15 degree tilted work surface (ergonomic + comfortable)
- Rapid replacement of style kits: A fixed "zero point" makes it possible to use different style kits without time consuming re-adjustments
- Special PFAFF sewing head for automatic units with tilt sewing head
- High productivity, due to constant maximum sewing speed (4,000 s.p.m.) without speed reduction in corners or on bartacks
- Optional machine height adjustment activated on the touch screen control panel P1
- Touch control panel P1 (with SD card reader) displays all machine parameters in easily understandable symbols
- Subclass - 16/031: Automatic unit with zigzag machine head for a higher output and shorter cycle times when sewing shirts, blouses and light jeans fabrics
- Optional small parts stacker



Output data:

Cycle time for one standard shirt pocket

8 sec. = effective output of 2,600 pockets / 8 hours  
(plain fabrics)

# PFAFF 3588-12/021

... The shirt pocket setter for all occasions

The classical solution for  
standard shirt pockets

## PFAFF 3588-12/021

With pocket style kit no. 95-300 250-70  
with integrated folding station

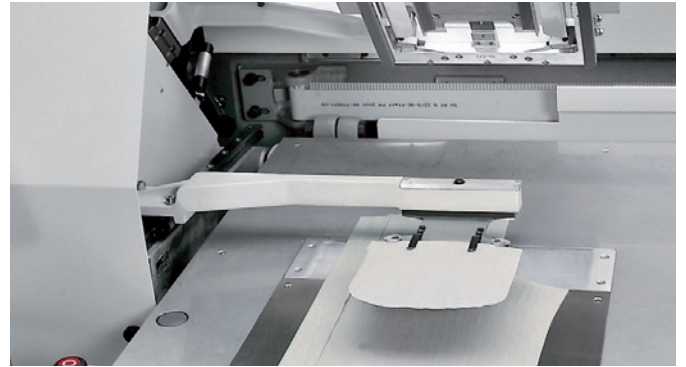

Further applications:



Pocket with label /  
additional seam for pen slot



Dress shield on sweatshirt  
materials

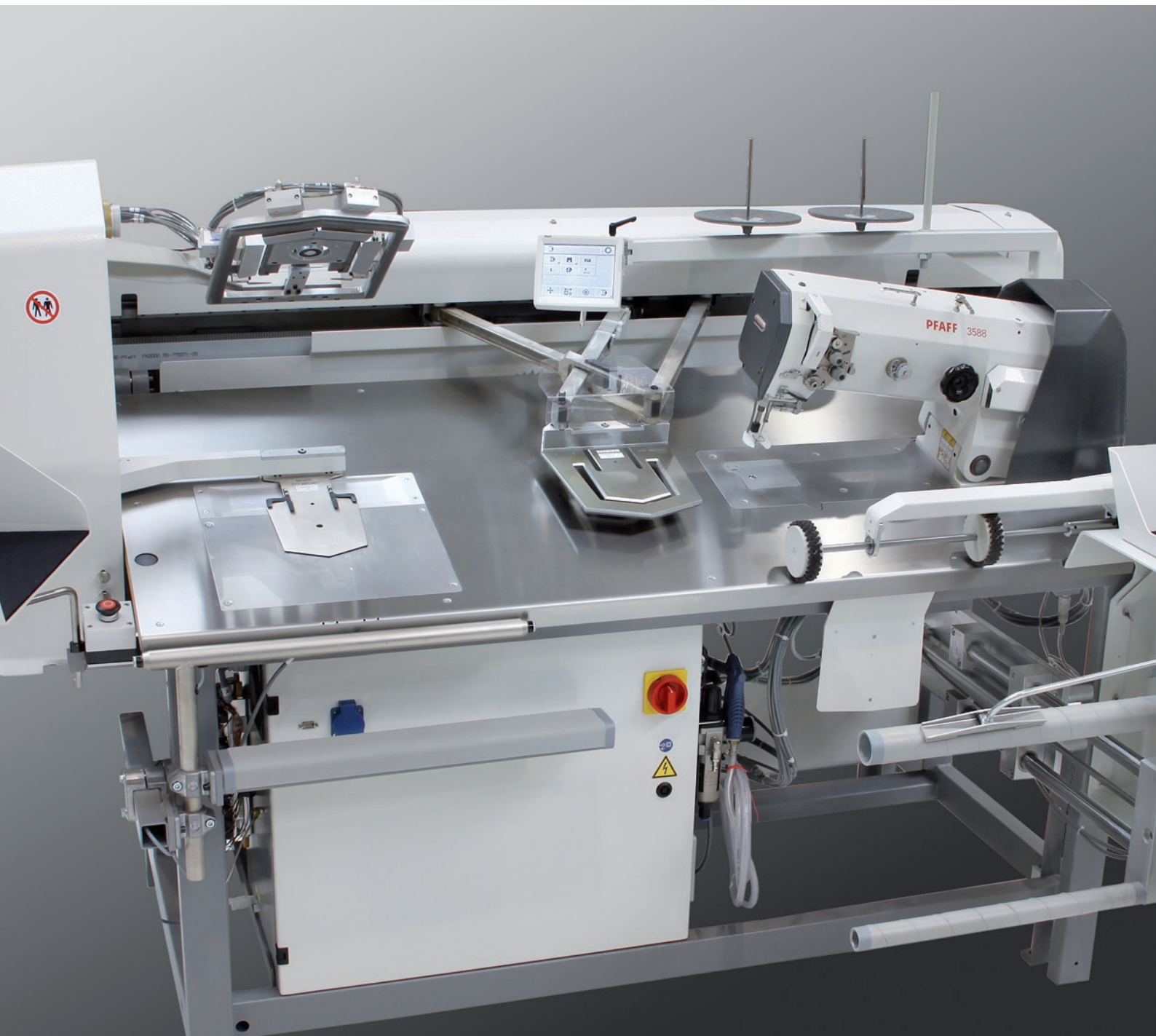

**Output data:**

Cycle time for one standard jeans pocket:

9 sec. = effective output of 2,400 pockets / 8 hours

# PFAFF 3588-05/020 and PFAFF 3588-15/020:

... The Jeans pocket setter - The economical answer in every situation

The classic solution for standard jeans pockets

PFAFF 3588-05/020 or 3588-15/020 in combination with pocket style kit no. 95-300 250-70 with integrated folding unit

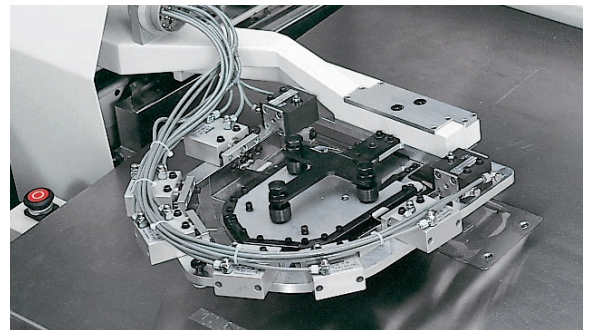

The economic solution with pocket style kit for pre-folded pockets

PFAFF 3588-05/020 or 3588-15/020 in combination with pocket style kit no. 95-300 308-70

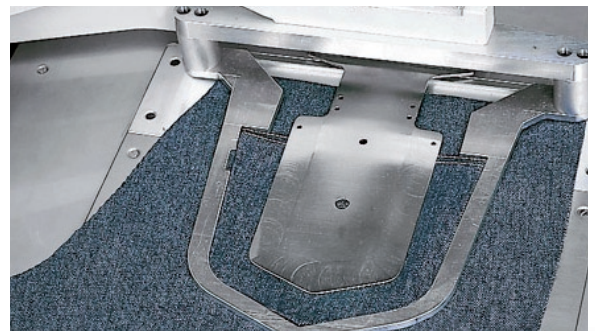

Further application:



Pocket with label

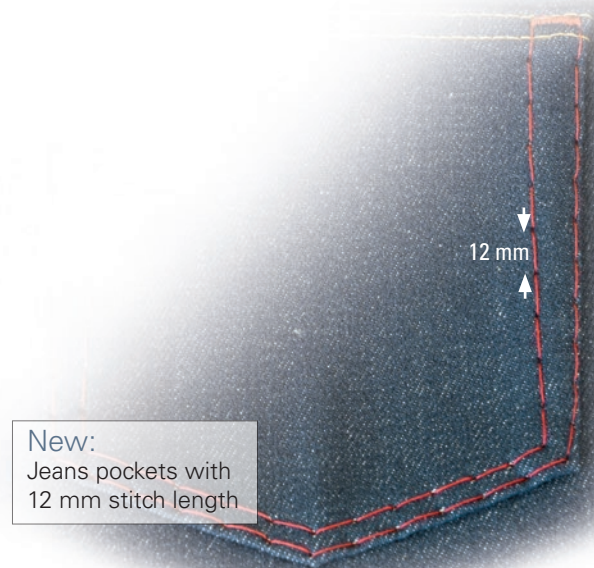

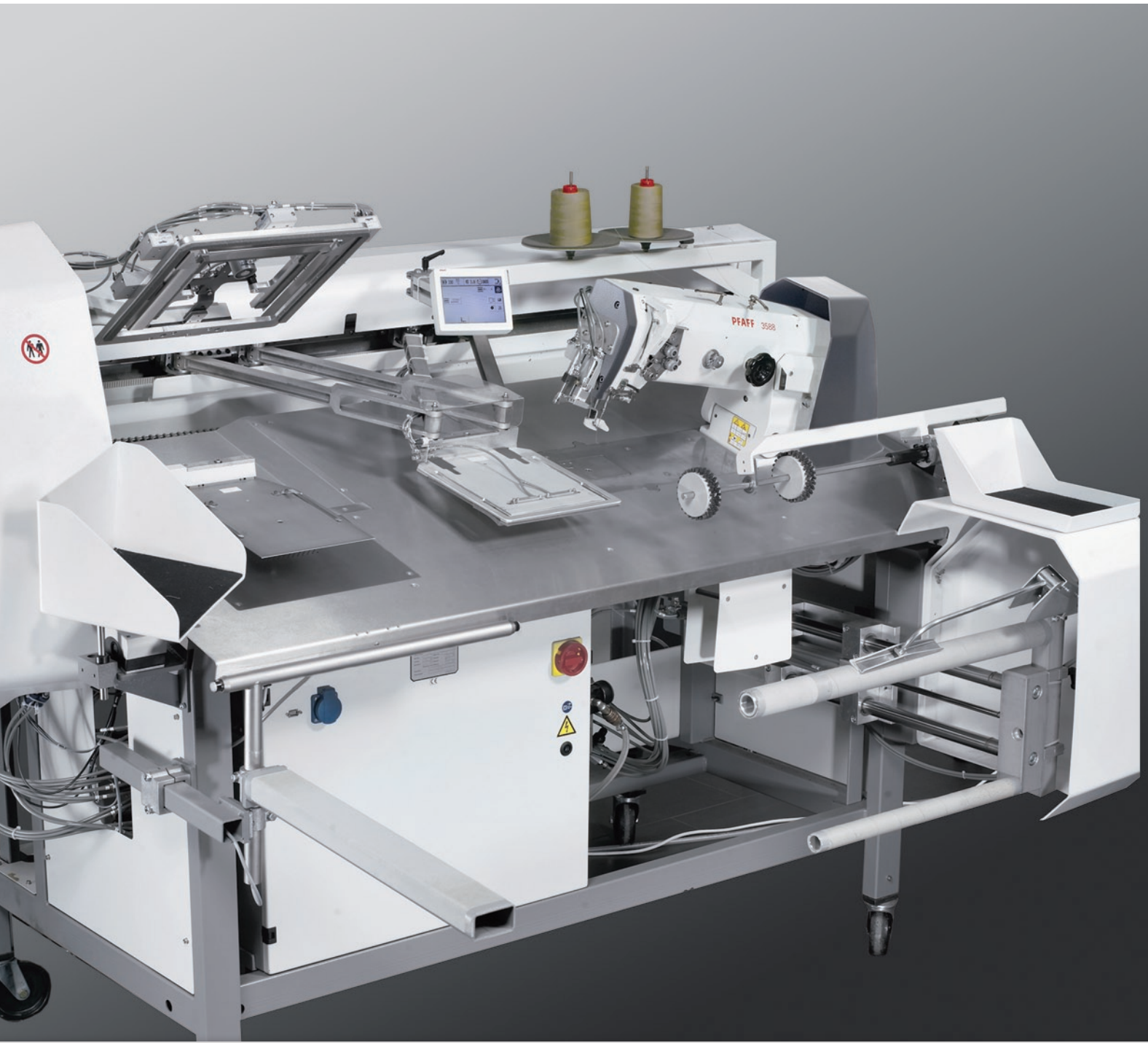

Bellow pocket - one sided or double sided

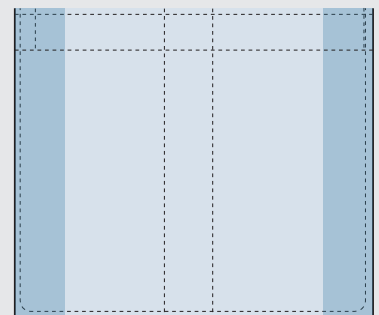
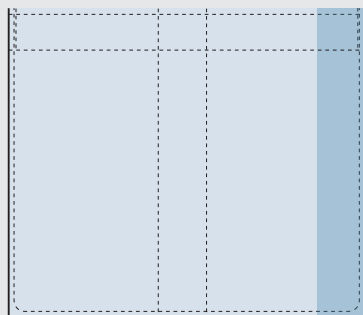
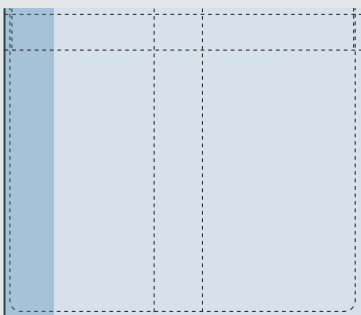



# PFAFF 3588 Cargo (for bellow pockets)\*

... Efficient attaching of side pockets

Bellow pockets (work wear, sports wear and military garments)

## Bellow pocket - one sided:

Version for bellow on left and/or right side

Basic kit no. 95-778 494-70/893  
and pocket style kit no. 95-300 300-70

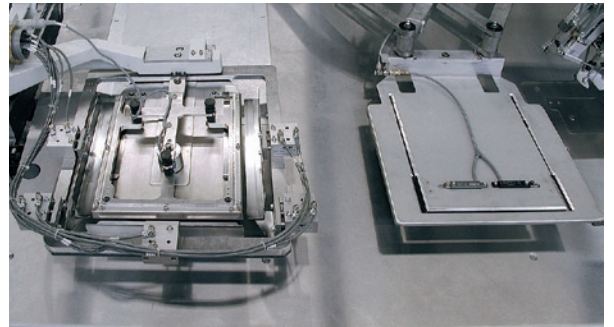

## Bellow pocket - L-Shape:

Version for bellows on the left or right side and bottom of pocket

Basic kit no. 95-778 494-70/893  
and pocket style kit no. 95-300 300-70



**New**

## New: Cargo Plus (U-Shape):

Version for bellows on the left, right and bottom side of pocket

Pocket style kit no. 95-300 345-70

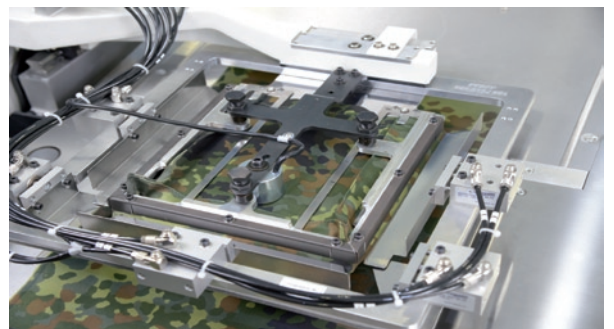

\* basic machine: PFAFF 3588-05/020 or PFAFF 3588-15/020

## Cargo - L-Shape

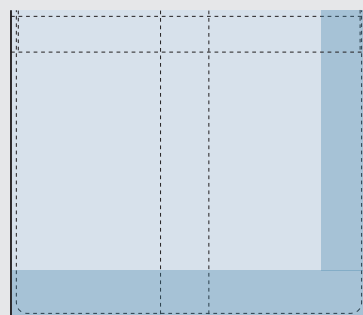
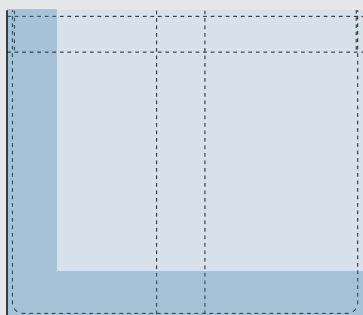

## Cargo Plus

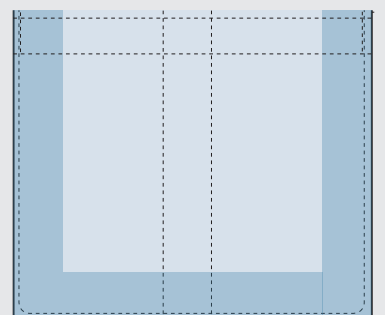

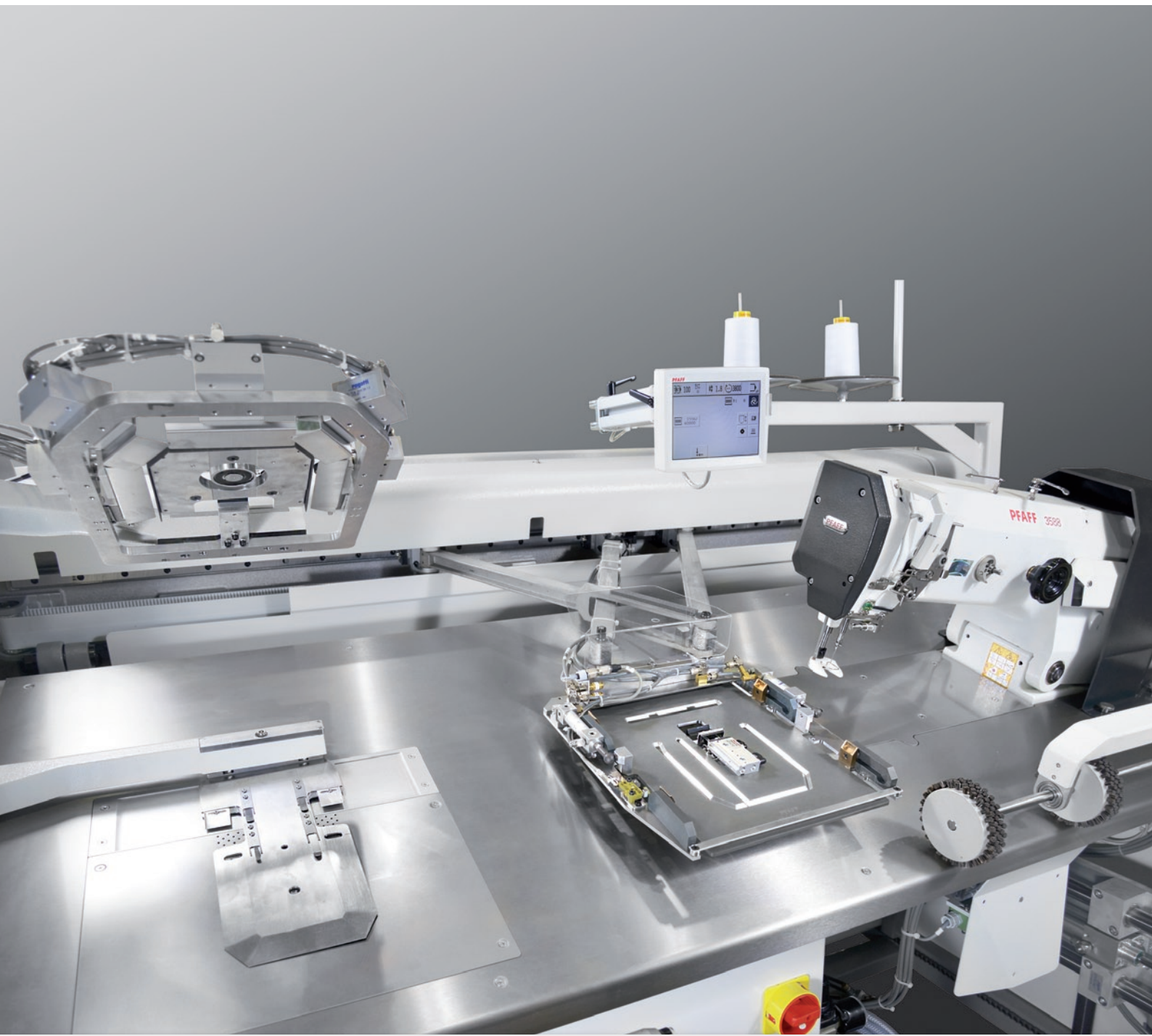

# PFAFF 3588 Flap

... Attaching pocket with flap in one operation

## Open flap (Shirt)

PFAFF 3588-12/021 or 3588-16/031  
with basic kit no. 95-776 422-90  
and pocket style kit no. 95-300 256-70:

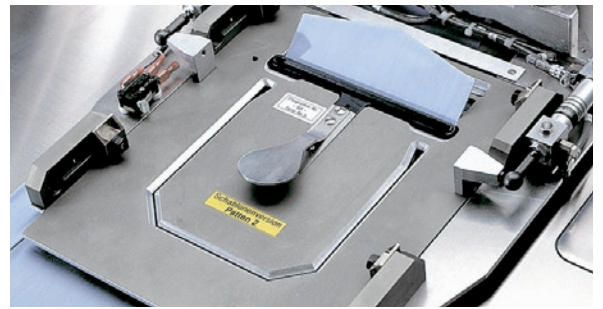

## Open flap (Jeans)

PFAFF 3588-05/020  
with basic kit no. 95-776 422-90 and  
pocket style kit no. 95-300 256-70:

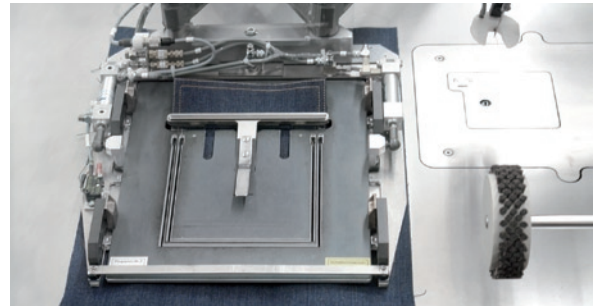

## Ready made flap (Shirt + Jeans)

PFAFF 3588-12/021 or 3588-16/031  
with basic kit no. 95-854 082-90  
and pocket style kit no. 95-300 330-70:

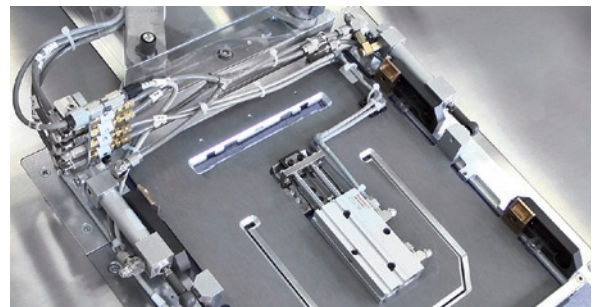

Shirt pocket with flap



Flap + additional seam  
for pen slot



Flap on jeans trouser

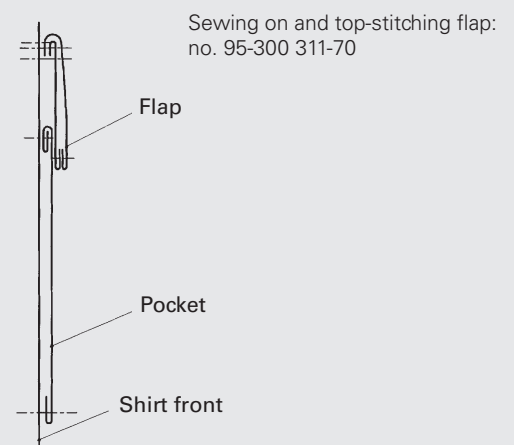
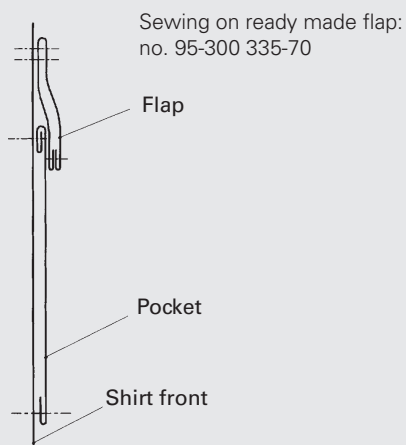

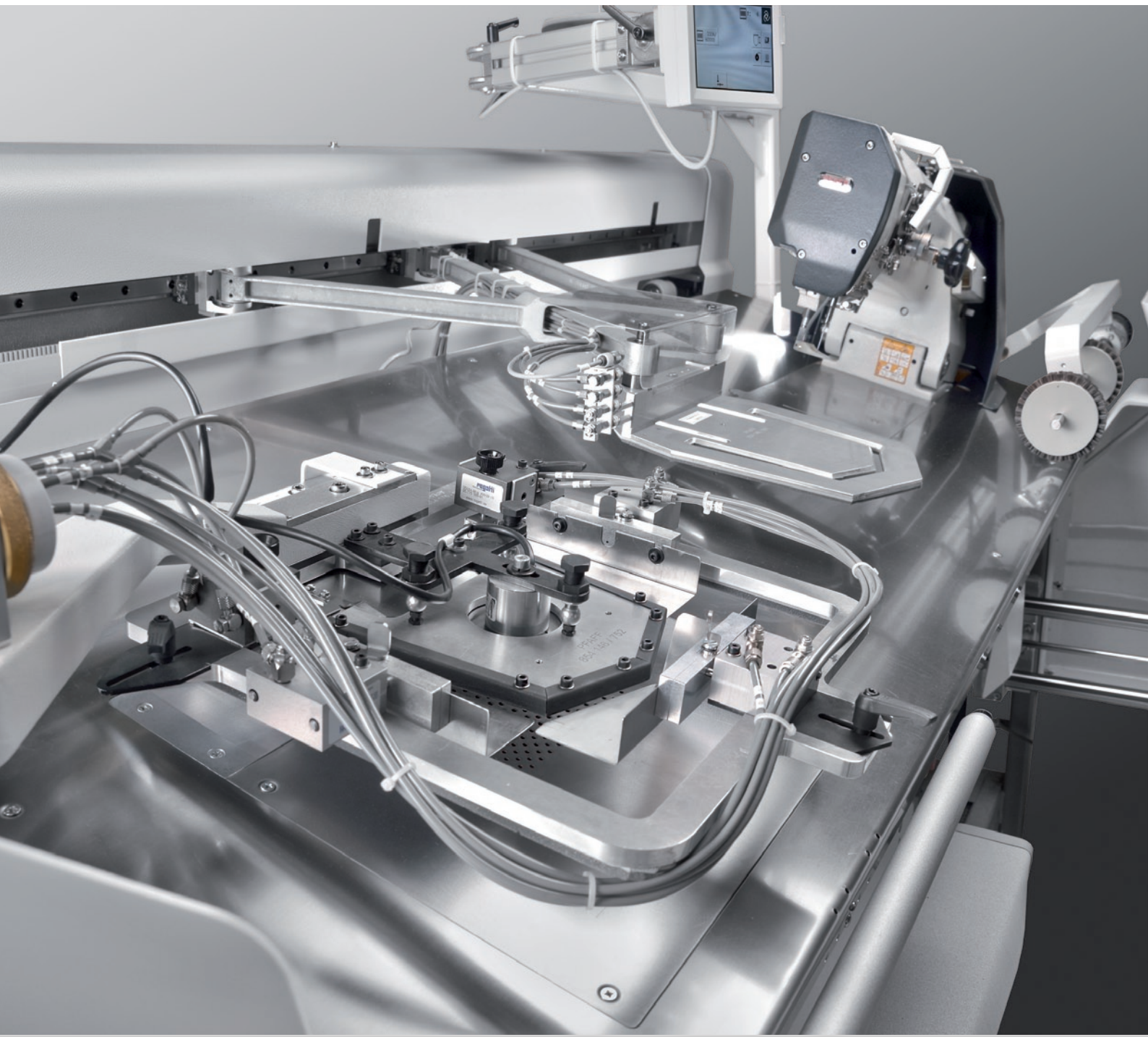

# New: Eco-Flex style kit

... flexible and cost-efficient concept for style kits for automatic jeans pocket setter

**Eco-Flex style kit** consisting of:

## Universal U-plate (outer frame)

- One-time purchase ( $\approx$  35% of the original costs of a standard style kit)
- Universal outer frame can be used for pocket size range 100 x 100 mm up to 200 x 200 mm. (Larger pocket sizes on request)

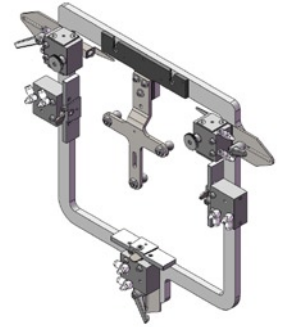

## Shape depending style kit

- For pocket styles 04 and 06 (others on request)
- Quick exchange of pocket style and or size to reduce downtime in your production when changing from one style or size to another
- Significantly reduced cost of new style sets due to limited number of shape depending conversion parts required
- No tools required for style set changes

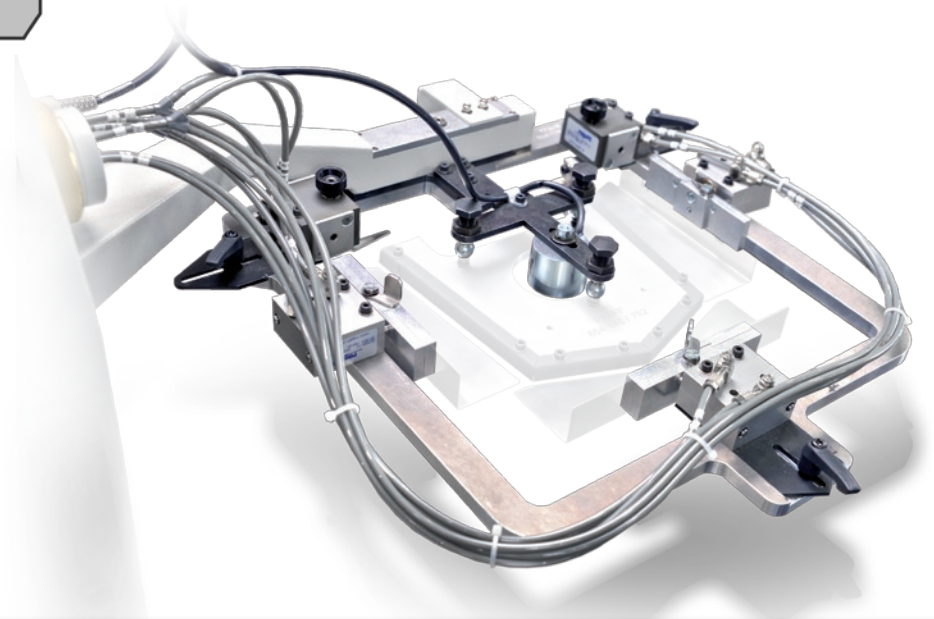
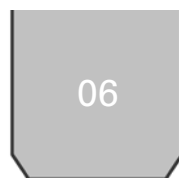
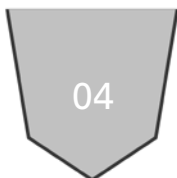
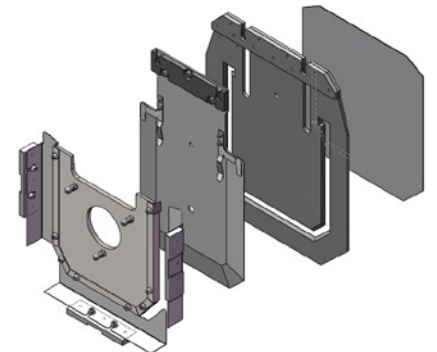

# Transfer plate with retractable sliders

**Style kit** including transfer plate with retractable sliders

Recommended for:

- Double seam in light and medium heavy fabrics and stretch fabrics
- Achieving seam margins  $< 2,4$  mm to the pocket edges

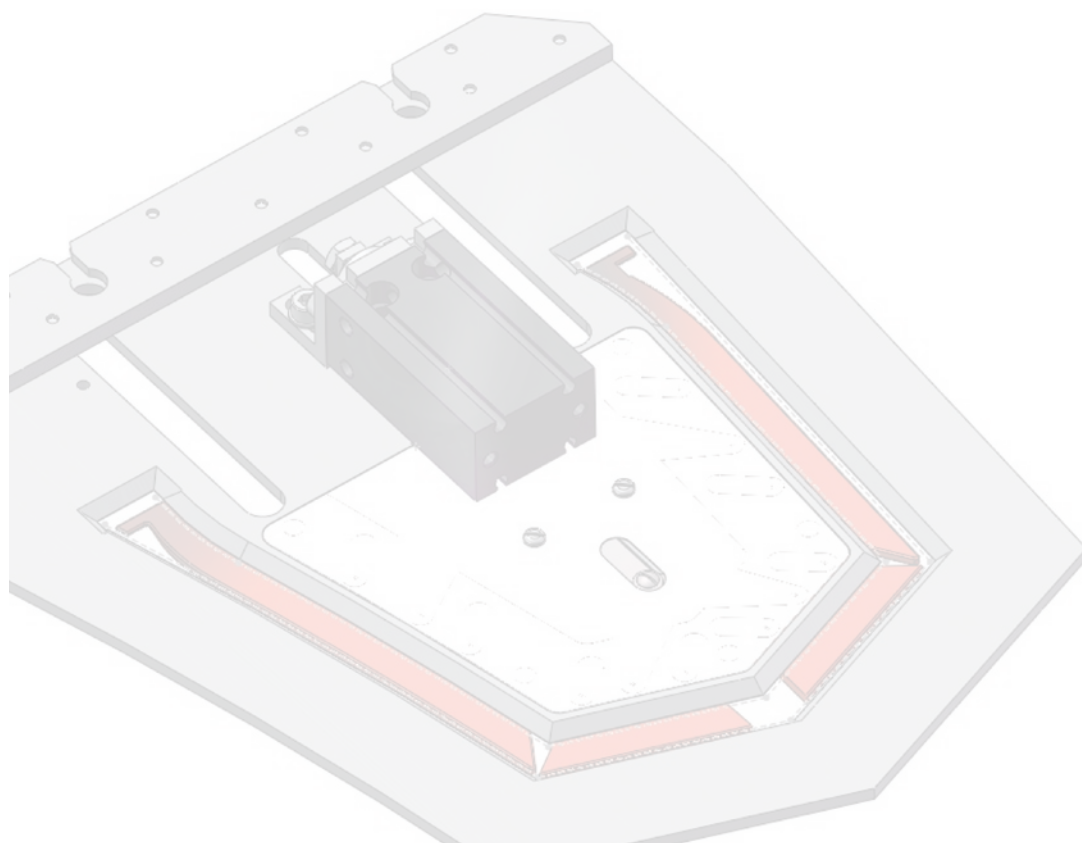
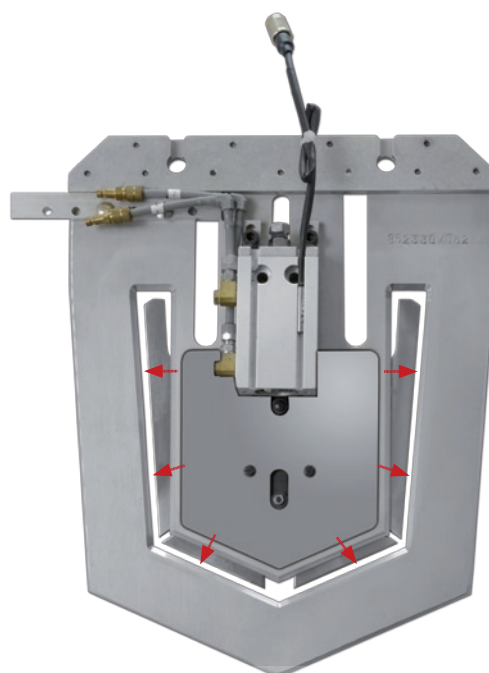
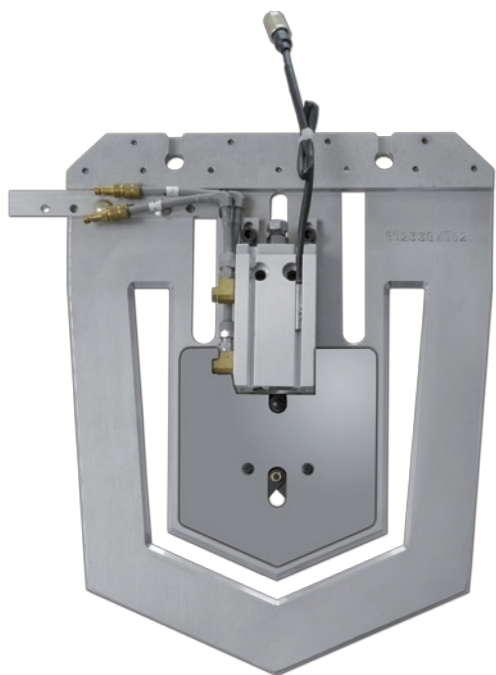

# Bell-shaped pocket

**Pocket plate** (Style kits no. 60 - 63)

Recommended for:

- For pocket shapes that are wider at the bottom than at the opening.
- The pocket plate is equipped with slides that may be swiveled in for easy removal despite the narrow opening. The slides fold without damaging the folded pocket.
- May be used for both the jeans and shirt version (single seam and double seam).

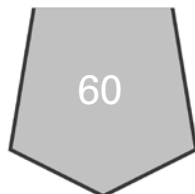
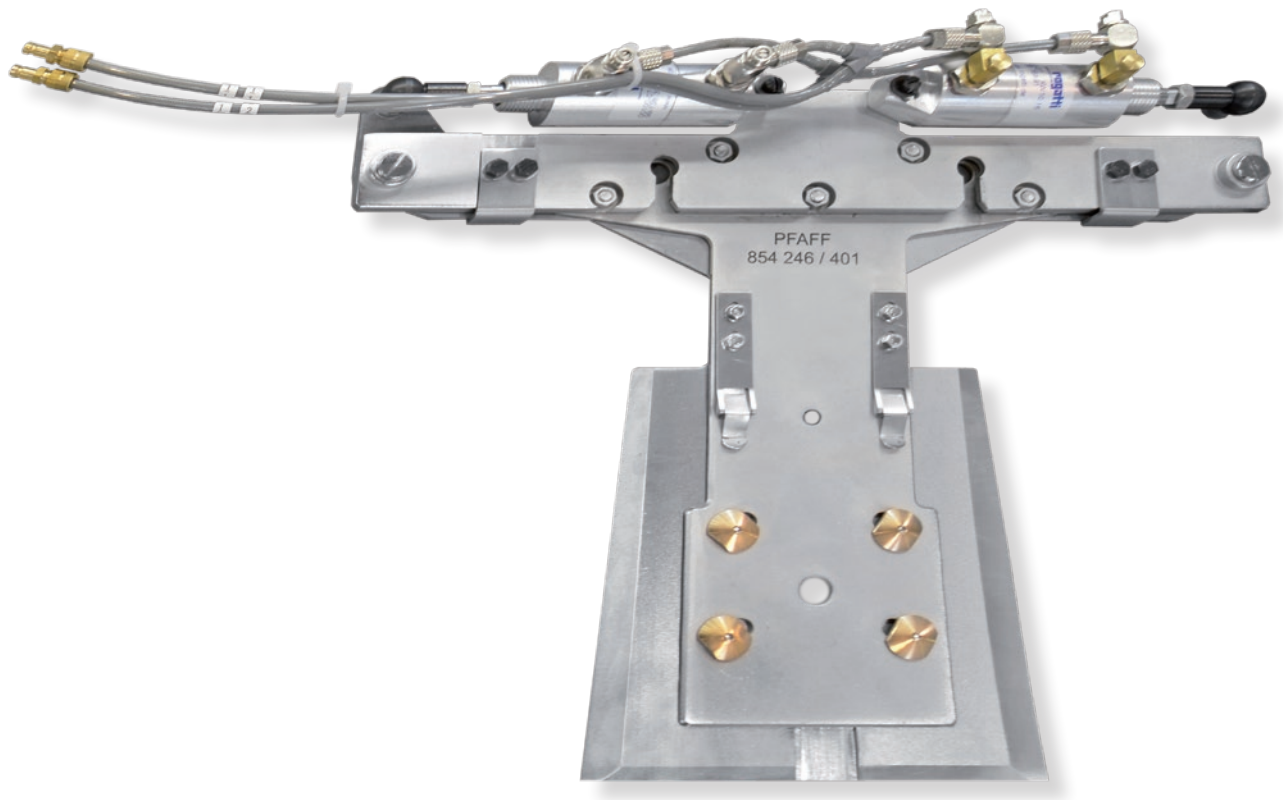

60

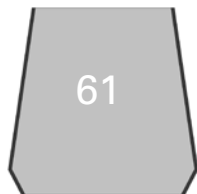

61

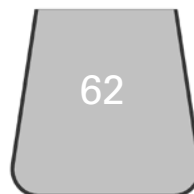

62

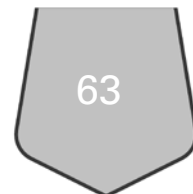

63

# Pocket styles

... a unique selection of sizes and styles

---

Symmetrical pockets:

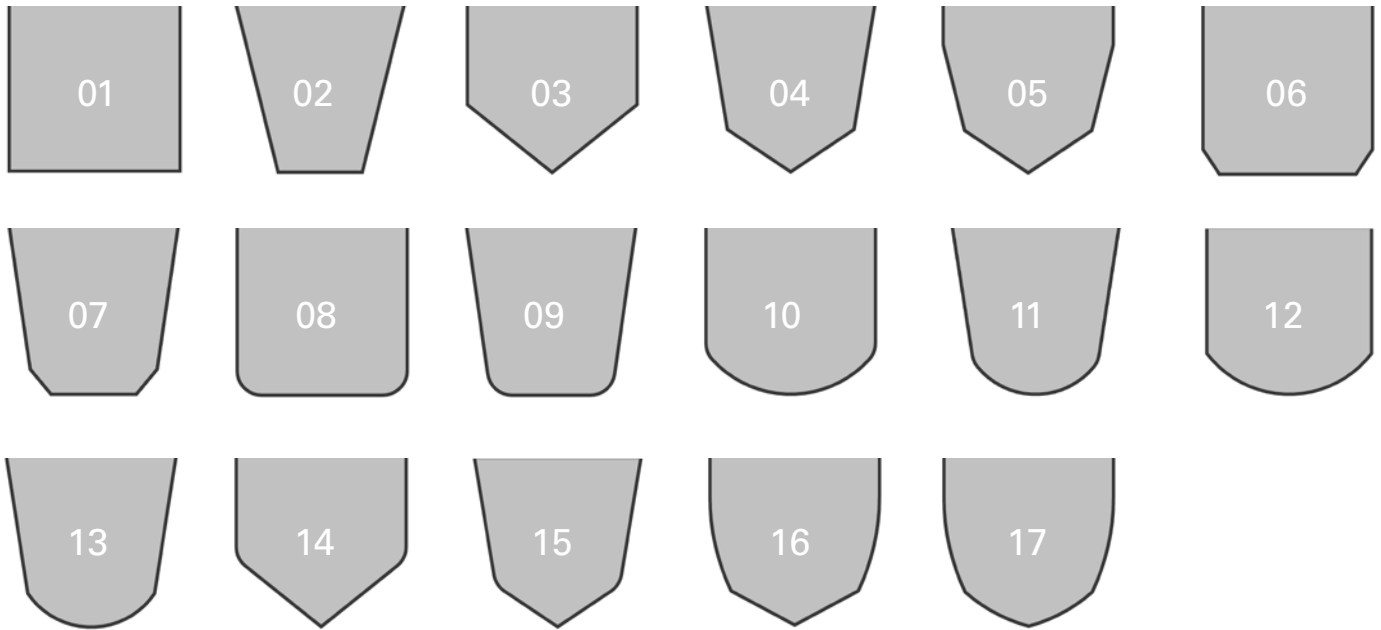

Asymmetrical pockets:

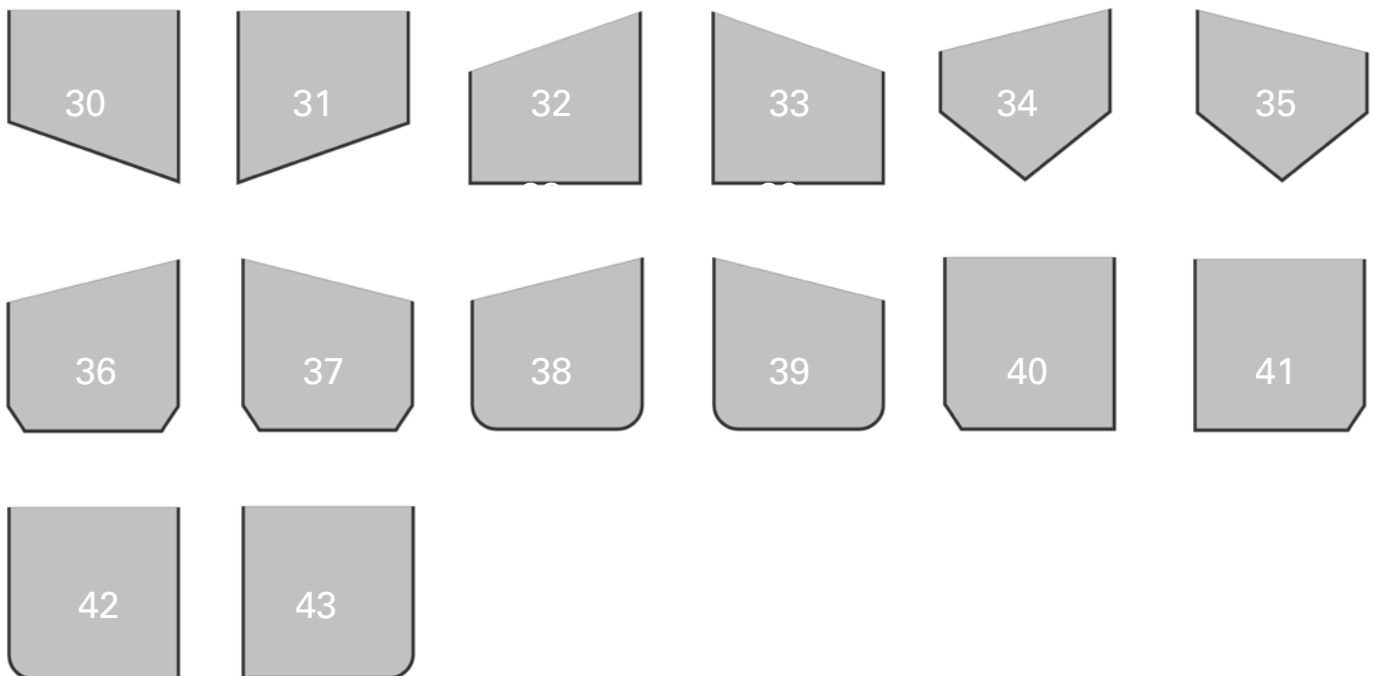

Bell-shaped pockets:

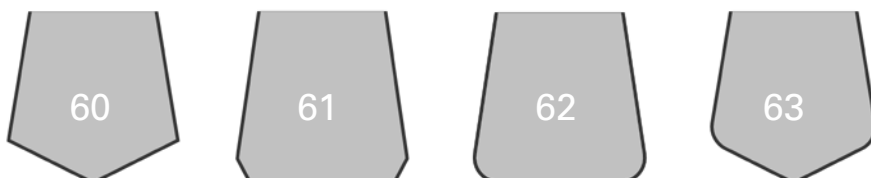



# Bartack styles

... configure your required bartack and pocket style



R-01



R-02



R-03



R-04



R-05



R-06

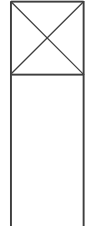

R-07



R-08



R-09



R-10



R-11



R-12

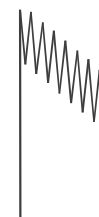

R-13

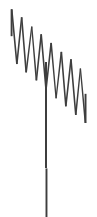

R-14

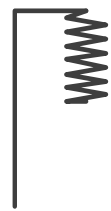

R-15



R-16



R-17



R-18



R-19

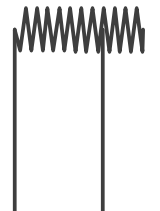

R-20

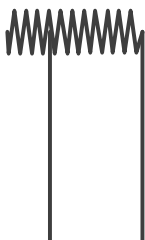

R-21

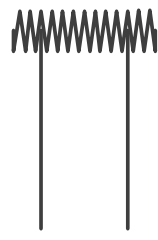

R-22

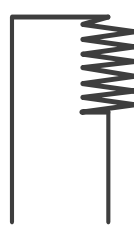

R-23

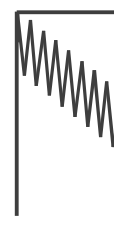

R-24

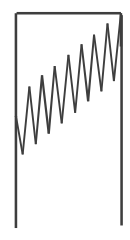

R-25

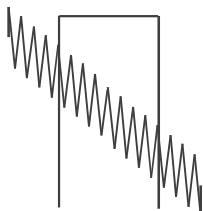

R-26

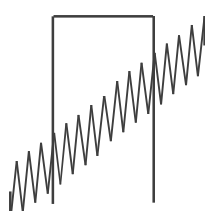

R-27

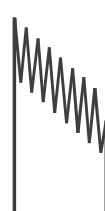

R-28

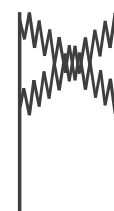

R-29

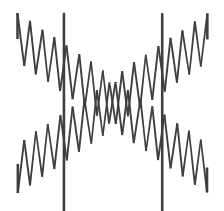

R-30

## Versions and style kits:









3588-12/021\*  
3588-22/021\*  
3588-16/031\*

3588-05/020\*  
3588-15/020\*

STYLE KIT FOR STANDARD POCKETS			
95-300 250-70	Pocket style kit for un-folded pockets (Folder, pocket plate, sewing jig)	●	●
STYLE KIT FOR POCKETS WITH OPEN FLAPS			
95-300 256-70	Pocket style kit for flaps (Folder + pocket plate)	●	●
95-776 422-90	Basic kit for attaching pockets with flaps (Max. pocket size: L: 200 mm, W: 180 mm)		
95-300 311-70	Sewing jig for attaching and top-stitching of open flaps		
STYLE KIT FOR POCKETS WITH READY-MADE FLAPS			
95-300 330-70	Pocket style kit for flaps (Folder + pocket plate)	●	●
95-854 082-90	Basic kit for attaching pockets with flaps (Max. pocket size: L: 200 mm, W: 180 mm)		
95-300 335-70	Sewing jig for attaching flaps		
STYLE KIT FOR BELLOW POCKETS (without flaps)			
95-300 300-70	Pocket style kit for bellow pockets - one sided, double sided or L-shape		●
95-778 494-70/893	Basic kit for bellow pockets – one sided, double sided or L-shape (Version for pleats on the transverse side and longitudinal side)		●
95-300 345-70	Pocket style kit for "Cargo Plus" bellow pockets		●
STYLE KIT FOR PRE-FOLDED POCKETS			
95-300 308-70	Pocket style kit for pre-folded pockets		●
95-776 633-90	Basic kit for pre-folded pockets		
95-776 535-70/895	Set of blanks for in-house production of pocket style kit		
ECO-FLEX STYLE KIT			
95-300 420-70	Universal U-plate (outer frame)		●
95-300 450-70	Parts-kit for Eco-Flex		●

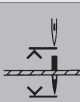
\* Each machine has to be equipped with one pocket style kit







## Technical data + specifications:

Types								
	Sewing area	Number of threads	Vertical hook, large	Horizontal hook, small	Needle positioning	Thread trimmer	Bobbin thread monitor	Presser foot lift
<b>-12/021</b> / Shirt	250x250	●		●	●	●	●	●
<b>-22/021</b> / Shirt	280x280	●		●	●	●	●	●
<b>-16/031</b> / Zigzag	250x250	●		●	●	●	●	●
<b>-05/020</b> / Jeans	250x250	●	●		●	●	●	●
<b>-15/020</b> / Jeans	280x280	●	●		●	●	●	●

## Optional equipment:

3588-12/021*	3588-05/020*
3588-22/021*	3588-15/020*
3588-16/031*	

95-775 577-70/893	Sewing head tilting mechanism for easy bobbin change	●	
<b>TRANSFER PLATE WITH RETRACTABLE SLIDERS</b> - recommended for a double seam in light + medium heavy fabrics as well as stretch fabrics and seam depths < 2,4 mm (jeans)			
95-776422-90	Basic kit	●	●
95-300 255-70	Sewing jig with variable sewing slot		
<b>DEVICE FOR PROCESSING LABELS</b>			
95-776 566-90	Basic kit for labels and bell-shaped pockets	●	●
95-300 315-70	Label positioning device - left pocket side	●	●
95-300 316-70	Label positioning device - right pocket side	●	●
<b>DEVICE FOR PROCESSING BELL-SHAPED POCKETS</b>			
95-776 566-90	Basic kit for bell-shaped pockets	●	●
95-300 307-70	Pocket plate (splitted) for bell-shaped pockets		●
<b>DEVICE FOR JIG MONITORING</b> (if required each pocket style kit needs to be equipped)			
95-776 519-90	Sewing jig monitoring	●	●
91-291 930-90	Basic kit		
91-291 919-91	<b>Solenoid</b> - to support the folding process	●	●
91-291 920-90	Basic kit (magnet)		
95-775 883-70/893	<b>Height-adjusting device</b> (motor driven)	●	●
95-775 715-90	<b>Feed rollers</b> (4 pieces)	●	●

Types		SD-Card		 - System	 mm		 - Nm
	Large part stacker	Data storage	Stitches per minute, max.	Needle system	Stitch length, max.	Needle cooling	Needle size
<b>-12/021</b> / Shirt	●	●	4.000	134	8	●	70-110
<b>-22/021</b> / Shirt	●	●	3.600	134	8	●	70-110
<b>-16/031</b> / Zigzag	●	●	4.000	134	8	●	70-110
<b>-05/020</b> / Jeans	●	●	4.000	134 MR	8	●	110-160
<b>-15/020</b> / Jeans	●	●	3.600	134-35 SERV7	8	●	110-160

## Technical Data:

**Stitch type:**

301 (lockstitch)

**Connection voltage:**

230 V single-phase a.c.  
50/60 Hz

**Electric power consumption:**

2.2 kw/h

**Working pressure:**

6 bar

**Air consumption:**

approx. 25 l/cycle

**Net weight:**

approx. 650 kg

**Dimensions (mm):**

Length: approx. 2.250

Breadth: approx. 1.150

Height: approx. 1.450

Height of front : 870 to 1.170  
edge of table

**PFAFF Industriesysteme  
und Maschinen GmbH**

Hans-Geiger-Str. 12 – IG Nord  
D-67661 Kaiserslautern

Telefon: +49-6301/3205-0

Telefax: +49-6301/3205-3171

E-mail: [info@pfaff-industrial.com](mailto:info@pfaff-industrial.com)

Printed in Germany  
engl.  
296-12-18228 09/18