

PFAFF[®] Industrial



POWERLine
2542/2545/2546



POWERline 2542/2545/2546

Revolutionary...

The combination of revolutionary design and innovative engineering has led to the development of something quite special, extraordinary – something, which will influence the future of the sewing machine. An impressive example for such a far-reaching combination is the POWERLINE 2542/2545/2546 – a line of heavy duty special high-speed sewing machines with vertical hook.

2542: double-needle version with compound feed

2545: single-needle version with unison feed (bottom-, needle- and alternating top feed)

2546: double-needle version with unison feed (bottom-, needle- and alternating top feed)

Clear and precise functions with ergonomically arranged control elements are the outstanding features of this series, for which PFAFF won the Interzum Innovations-Award 2007 in the "Best of the Best" category. The machine achieves an equally high stitch quality on top-stitching work in the visible areas and on assembly seams in the non-visible areas. Top sewing results are guaranteed in the sections home upholstery, automotive, jeans, tents, curtains or awnings. With the largest arm clearance in its class, the machine guarantees excellent handling. Technical features, like the programmable multi-switch or the new "winding assistant" support the working flexibility and make the POWERLINE a multi-feature machine with "excellent benefits".



PFAFF



Overview of the 2542/2545/2546

The POWERLINE 2542/2545/2546 is available in the following versions with varying equipment:

	2542 PLUS	2545/46 BASIC	2545/46 CLASSIC	2545/46 PLUS
Compound feed	●			
Unison feed with height adjustment of the bottom feeder		●	●	●
Unison feed with engageable lifting motion of the bottom feeder		○	○	○
Vertical hook, large (for threads up to size 10/3 syn.)	●	●	●	●
Vertical hook, XXL extra large for threads up to size 10/3 syn. (G-Hook)		○	○	○
Thread trimmer, < 13 mm thread ends (-900/81)	●		●	●
Thread trimmer, < 5 mm thread ends (-900/82)			○	○
Thread nipper, controlled (-909/12)	●		●	●
Presser foot lift, manual by knee lever		●		
Presser foot lift, electro-pneumatic (-910/04)	●		●	●
Manual backtacking with hand lever	●	●	●	●
Automatic backtacking, electro-pneumatic (-911/35)	●		●	●
1 pre-selectable stitch length		●	●	
2 pre-selectable stitch lengths, alternately switchable (2545/46: -918/29, 2542: -918/26)	●			●
2 pre-selectable thread tensions (per needle), one can be switched on manually		●		
2 pre-selectable thread tensions (per needle), one can be switched on electro-pneum. by knuckle switch	●		●	●
Top feed stroke is manually adjustable up to 9 mm		●	●	
2 top feed strokes are manually adjustable, alternately switchable (-918/29)				●
Oil-level indicator	●	●	●	●
Oil-level indicator on the display, with warning light on sewing head	●		●	●
Sewing feet pressure, manually adjustable	●	●	●	●
DC motor P45 PD2-L		○		
DC motor P74 ED-L*	●		●	●
Control panel BDF-PicoTop	●		●	●
Bobbin thread monitor with stitch counter and LED display	●		●	●
Integrated panel with multi-function buttons & programmable multi-switch	●		●	●
Built in LED sewing light in the machine head, dimmable	●	○	●	●
Bobbin thread winder	●	●	●	●
Attachment slide, holder	●	●	●	●
Skip stitch detection (SSD) to control the quality of the seam ¹⁾			○	○
Bobbin thread monitoring with thread detection (-926/06)			○	○
Monitoring of slide plate / Safety device for the start ²⁾			○	○
Overload safety clutch	●	●	●	●
Control element safety device			○	○

* Necessary for thread trimmer, backtacking, thread nipper, presser foot lift, 2 switchable stitch lengths, 2 switchable top feed strokes

¹⁾²⁾ Only in combination with the bobbin thread monitor by the sensor

● standard
○ option

Versions of the 2545*

2545 BASIC

equipped with:

Large vertical hook for threads up to 10/3

Special single-needle high-speed seamer with unison feed (lockstitch)

- Top feed stroke up to 9 mm, presser foot lift up to 20 mm, stitch length up to 12.0 mm
- Max. sewing speed 3,800 stitches/min.
- Overload safety clutch

2545-G BASIC

equipped with:

Extra large vertical hook with 70% more thread capacity, for threads up to 10/3 (G)

Special single-needle high-speed seamer with unison feed (lockstitch)

- Top feed stroke up to 9 mm, presser foot lift up to 20 mm, stitch length up to 12.0 mm
- Max. sewing speed 3,400 stitches/min.
- Overload safety clutch

2545 CLASSIC

equipped with:

- 900/81: Thread trimmer
- 909/12: Thread nipper, controlled
- 910/04: Automatic presser foot lift
- 911/35: Automatic backtacking device
- 925/03: Air filter lubricator

Large vertical hook for threads up to 10/3

Special single-needle high-speed seamer with unison feed (lockstitch)

- Second thread tension electro-pneumatically controlled
- Adjustable top feed stroke up to 9 mm without quick change stepping control with automatic speed setting
- Presser foot lift up to 20 mm, 1 stitch length up to 12.0 mm
- Max. sewing speed 3,800 stitches/min.
- DC motor PFAFF P74 ED-L
- Overload safety clutch
- Built in LED sewing light in the machine head

2545-G CLASSIC

equipped with:

- 900/81: Thread trimmer
- 909/12: Thread nipper, controlled
- 910/04: Automatic presser foot lift
- 911/35: Automatic backtacking device
- 925/03: Air filter lubricator

Extra large vertical hook with 70% more thread capacity, for threads up to 10/3 (G)

Special single-needle high-speed seamer with unison feed (lockstitch)

- Second thread tension electro-pneumatically controlled
- Adjustable top feed stroke up to 9 mm without quick change stepping control with automatic speed setting
- Presser foot lift up to 20 mm, 1 stitch length up to 12.0 mm
- Max. sewing speed 3,400 stitches/min.
- DC motor PFAFF P74 ED-L
- Overload safety clutch
- Built in LED sewing light in the machine head

2545-900/82 CLASSIC

equipped with:

- 900/82: Thread trimmer for short thread ends (Remaining thread length = < 5 mm)
- 900/81: Thread trimmer
- 909/12: Thread nipper, controlled
- 910/04: Automatic presser foot lift
- 911/35: Automatic backtacking device
- 925/03: Air filter lubricator

Large vertical hook for threads up to 15/3

Special single-needle high-speed seamer with unison feed (lockstitch)

- Second thread tension electro-pneumatically controlled
- Adjustable top feed stroke up to 9 mm without quick change stepping control with automatic speed setting
- Presser foot lift up to 20 mm, 1 stitch length up to 9.0 mm
- Max. sewing speed 3,800 stitches/min.
- DC motor PFAFF P74 ED-L
- Overload safety clutch
- Built in LED sewing light in the machine head

* requested parts kit must be defined when the machine will be configured (Versions see page 16 - 21)

Versions of the 2545*

2545-G-900/82 CLASSIC

equipped with:

- 900/82: Thread trimmer for short thread ends (Remaining thread length = < 5 mm)
- 900/81: Thread trimmer
- 909/12: Thread nipper, controlled
- 910/04: Automatic presser foot lift
- 911/35: Automatic backtacking device
- 925/03: Air filter lubricator

Extra large vertical hook with 70% more thread capacity, for threads up to 15/3 (G)

Special single-needle high-speed seamer with unison feed (lockstitch)

- Second thread tension electro-pneumatically controlled
- Adjustable top feed stroke up to 9 mm without quick change stepping control with automatic speed setting
- Presser foot lift up to 20 mm, 1 stitch length up to 9.0 mm
- Max. sewing speed 3,400 stitches/min.
- DC motor PFAFF P74 ED-L
- Overload safety clutch
- Built in LED sewing light in the machine head

2545 PLUS

equipped with:

- 900/81: Thread trimmer
- 909/12: Thread nipper, controlled
- 910/04: Automatic presser foot lift
- 911/35: Automatic backtacking device
- 925/03: Air filter lubricator
- 918/29: Switch gear for 2 stitch length + 2 top feed strokes

Large vertical hook for threads up to 10/3

Special single-needle high-speed seamer with unison feed (lockstitch)

- Second thread tension electro-pneumatically controlled
- Adjustable top feed stroke up to 9 mm WITH quick change stepping control with automatic speed setting
- Presser foot lift up to 20 mm, 1 stitch length up to 12.0 mm
- Max. sewing speed 3,800 stitches/min.
- DC motor PFAFF P74 ED-L
- Overload safety clutch
- Built in LED sewing light in the machine head

2545-900/82 PLUS

equipped with:

- 900/82: Thread trimmer for short thread ends (Remaining thread length = < 5 mm)
- 909/12: Thread nipper, controlled
- 910/04: Automatic presser foot lift
- 911/35: Automatic backtacking device
- 925/03: Air filter lubricator
- 918/29: Switch gear for 2 stitch length + 2 top feed strokes

Large vertical hook for threads up to 15/3

Special single-needle high-speed seamer with unison feed (lockstitch)

- Second thread tension electro-pneumatically controlled
- Adjustable top feed stroke up to 9 mm WITH quick change stepping control with automatic speed setting
- Presser foot lift up to 20 mm, 1 stitch length up to 9.0 mm
- Max. sewing speed 3,800 stitches/min.
- DC motor PFAFF P74 ED-L
- Overload safety clutch
- Built in LED sewing light in the machine head

2545-G PLUS

- 900/81: Thread trimmer
- 909/12: Thread nipper, controlled
- 910/04: Automatic presser foot lift
- 911/35: Automatic backtacking device
- 925/03: Air filter lubricator
- 918/29: Switch gear for 2 stitch length + 2 top feed strokes

Extra large vertical hook with 70% more thread capacity, for threads up to 10/3 (G)

Special single-needle high-speed seamer with unison feed (lockstitch)

- Second thread tension electro-pneumatically controlled
- Adjustable top feed stroke up to 9 mm WITH quick change stepping control with automatic speed setting
- Presser foot lift up to 20 mm, 1 stitch length up to 12.0 mm
- Max. sewing speed 3,400 stitches/min.
- DC motor PFAFF P74 ED-L
- Overload safety clutch
- Built in LED sewing light in the machine head

* requested parts kit must be defined when the machine will be configured (Versions see page 16 - 21)

Versions of the 2542/2546*

2542 PLUS

equipped with:

- 900/81: Thread trimmer
 - 909/12: Thread nipper, controlled
 - 910/04: Automatic presser foot lift
 - 911/35: Automatic backtacking device
 - 925/03: Air filter lubricator
 - 918/26: Switch gear for 2 stitch length
- Large vertical hook for threads up to 10/3

Special double-needle high-speed seamer with drop feed and needle feed

- Second thread tension electro-pneumatically controlled
- Presser foot lift up to 8 mm, 1 stitch length up to 6.0 mm
- Max. sewing speed 3,800 stitches/min. **
- DC motor PFAFF P74 ED-L
- Overload safety clutch
- Built in LED sewing light in the machine head

2546 BASIC

equipped with:

- Large vertical hook for threads up to 10/3

Special double-needle high-speed seamer with unison feed (lockstitch)

- Top feed stroke up to 9 mm, presser foot lift up to 20 mm, stitch length up to 12.0 mm
- Max. sewing speed 3,800 stitches/min. **
- Overload safety clutch

2546-G BASIC

equipped with:

- Extra large vertical hook with 70% more thread capacity, for threads up to 10/3 (G)

Special double-needle high-speed seamer with unison feed (lockstitch)

- Top feed stroke up to 9 mm, presser foot lift up to 20 mm, stitch length up to 12.0 mm
- Max. sewing speed 3,400 stitches/min. **
- Overload safety clutch

2546 PLUS

equipped with:

- 900/81: Thread trimmer
 - 909/12: Thread nipper, controlled
 - 910/04: Automatic presser foot lift
 - 911/35: Automatic backtacking device
 - 925/03: Air filter lubricator
 - 918/29: Switch gear for 2 stitch length + 2 top feed strokes
- Large vertical hook for threads up to 10/3

Special double-needle high-speed seamer with unison feed (lockstitch)

- Second thread tension electro-pneumatically controlled
- Adjustable top feed stroke up to 9 mm WITH quick change stepping control with automatic speed setting
- Presser foot lift up to 20 mm, 1 stitch length up to 12.0 mm
- Max. sewing speed 3,800 stitches/min. **
- DC motor PFAFF P74 ED-L
- Overload safety clutch
- Built in LED sewing light in the machine head

2546-G PLUS

equipped with:

- 900/81: Thread trimmer
 - 909/12: Thread nipper, controlled
 - 910/04: Automatic presser foot lift
 - 911/35: Automatic backtacking device
 - 925/03: Air filter lubricator
 - 918/29: Switch gear for 2 stitch length + 2 top feed strokes
- Extra large vertical hook with 70% more thread capacity, for threads up to 10/3 (G)

Special double-needle high-speed seamer with unison feed (lockstitch)

- Second thread tension electro-pneumatically controlled
- Adjustable top feed stroke up to 9 mm WITH quick change stepping control with automatic speed setting
- Presser foot lift up to 20 mm, 1 stitch length up to 12.0 mm
- Max. sewing speed 3,400 stitches/min. **
- DC motor PFAFF P74 ED-L
- Overload safety clutch
- Built in LED sewing light in the machine head

** Depending on needle gauge

Applications



Top-stitching applications in the automotive industry

Application:

Top-stitching (double-needle) on voluminous car seat covers

Parts sets / attachments:

parts kit 63/24 C N9
(needle distance: 8 mm)



Decorative ornamental stitching in the automotive industry

Application:

Ornamental stitching on centre section of back rests

Parts sets / attachments:

parts kit 6/14 C N9



Lap-felling seams in the automotive industry

Application:

One-sided top-stitching of the assembly seam for seat section and attached head-rest on front car seat

Parts sets / attachments:

parts kit 6/14 C N9
+ edge guide (91-156-765-91)

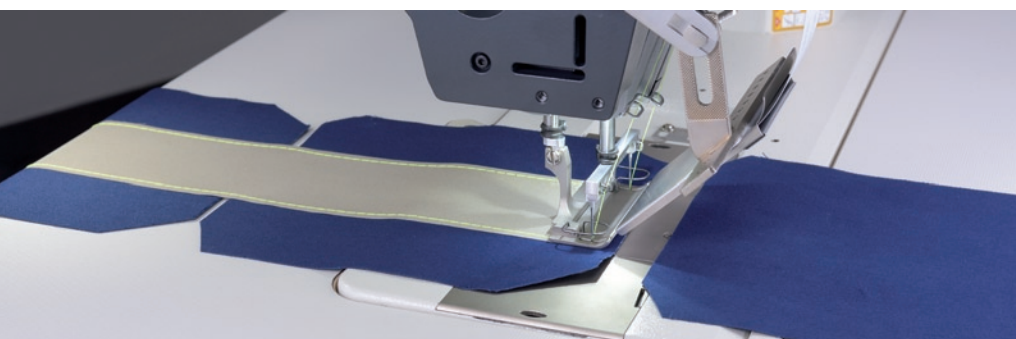

2542: Top-stitching of curtains, tents and awnings.

Application

Attaching a 70 mm tape

Parts sets / attachments:

parts kit 6/01 C N70
+ special feeding system

Innovative lubrication system

New lubrication system for accurate adjustment of the fresh oil supply to the hook. Prevents oil leakage (soiling of workpiece).

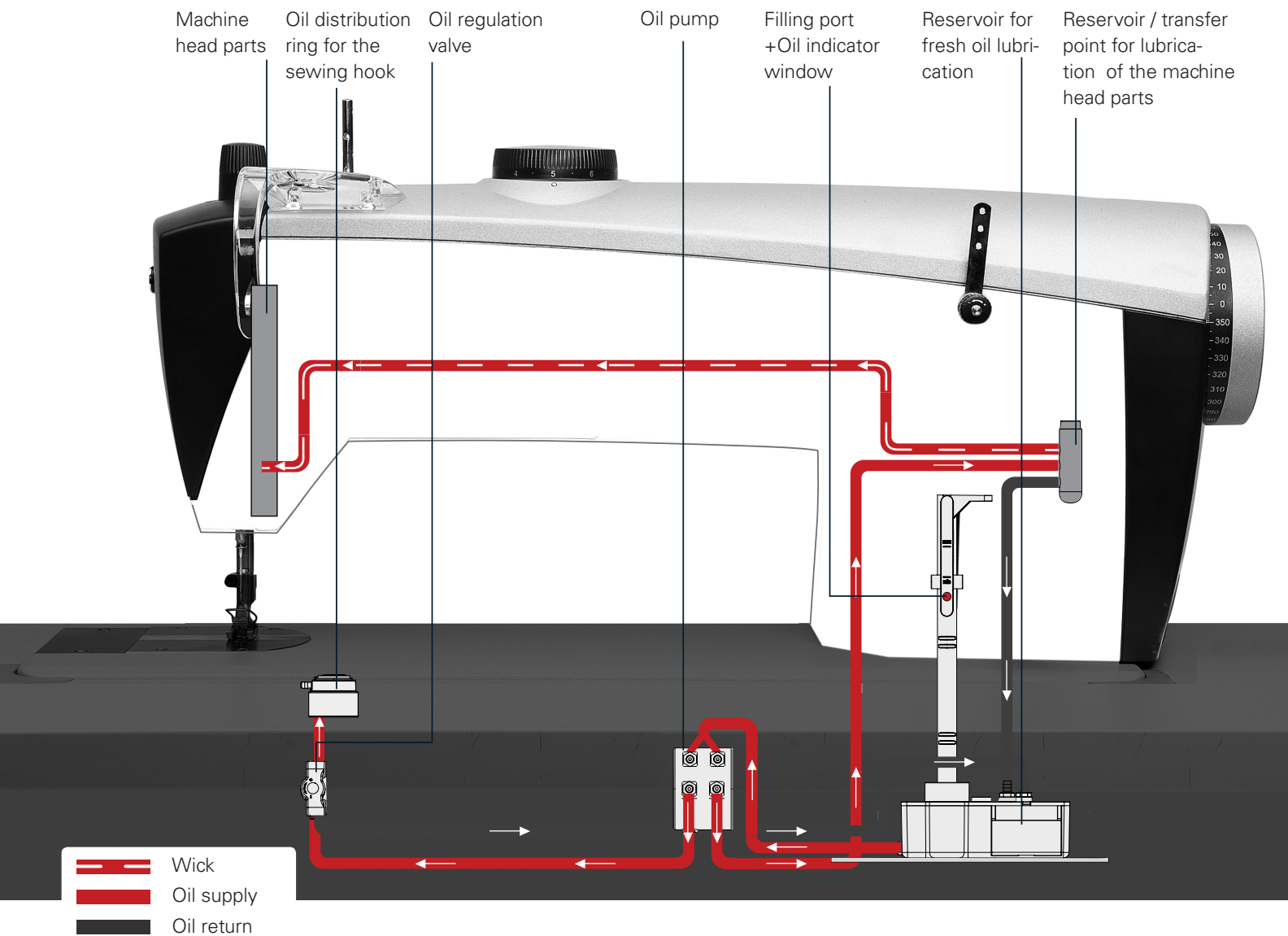

Features



①

Bobbin winder

Equipped with an aid for a secure and fast start of the bobbin winding process and within easy reach of the operator („winding assistant“)



②

Top feed stroke adjustment

Guarantees quick and accurate adjustment of the first and second top feed stroke. Adjustments are made in small increments.

- outer dial: up to 5 mm stroke

- inner dial: up to 9 mm stroke

Thread nipper

Ensures a neat seam start
(no thread tail on top of the
work piece)

③



LED light

Integrated in the sewing head

④

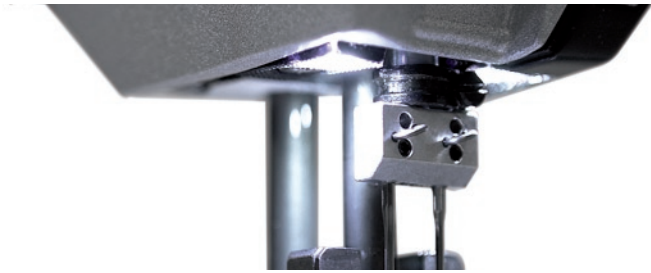

Increased top feed stroke

Up to 9 mm

Clearance under the sewing foot

Up to 20 mm

⑤-⑥



Hook saddle / Thread trimmer

Reliable and excellent cutting performance:

Threads up to 10/3 (metric) can be
cut without any problems

⑦



Large clearance

Under the machine arm
of 345 x 120 mm.

⑧



Scale disk

An adjustment aid for the mechanic:

- Needle bar rise
- Needle height
- Take-up lever

⑨



Features: control panels

From left to right:

Reverse sewing/intermediate backtacks

Needle position change (w/o trimming)

Recall preset top feed lift and adding second thread tension (programmable)

Backtack on/off

Recall preset stitch length

Second thread tension switched on / Switch for threading position (all pedal functions are blocked)

Safety switch:

Brings the machine in threading position and blocks all pedal functions. This prevents the operator from accidentally starting the machine and adds an additional safety feature.

From top to bottom:

Oil level warning

Bobbin thread control indicator

Programmable **multi-switch**

Functions, which are needed for the current sewing application, can be transferred to the soft switch (multi function switch) on the sewing head



Unique service concept

Easy and fast access to all adjustments:

The top arm cover and the head cover can be removed after loosening just 3 screws.

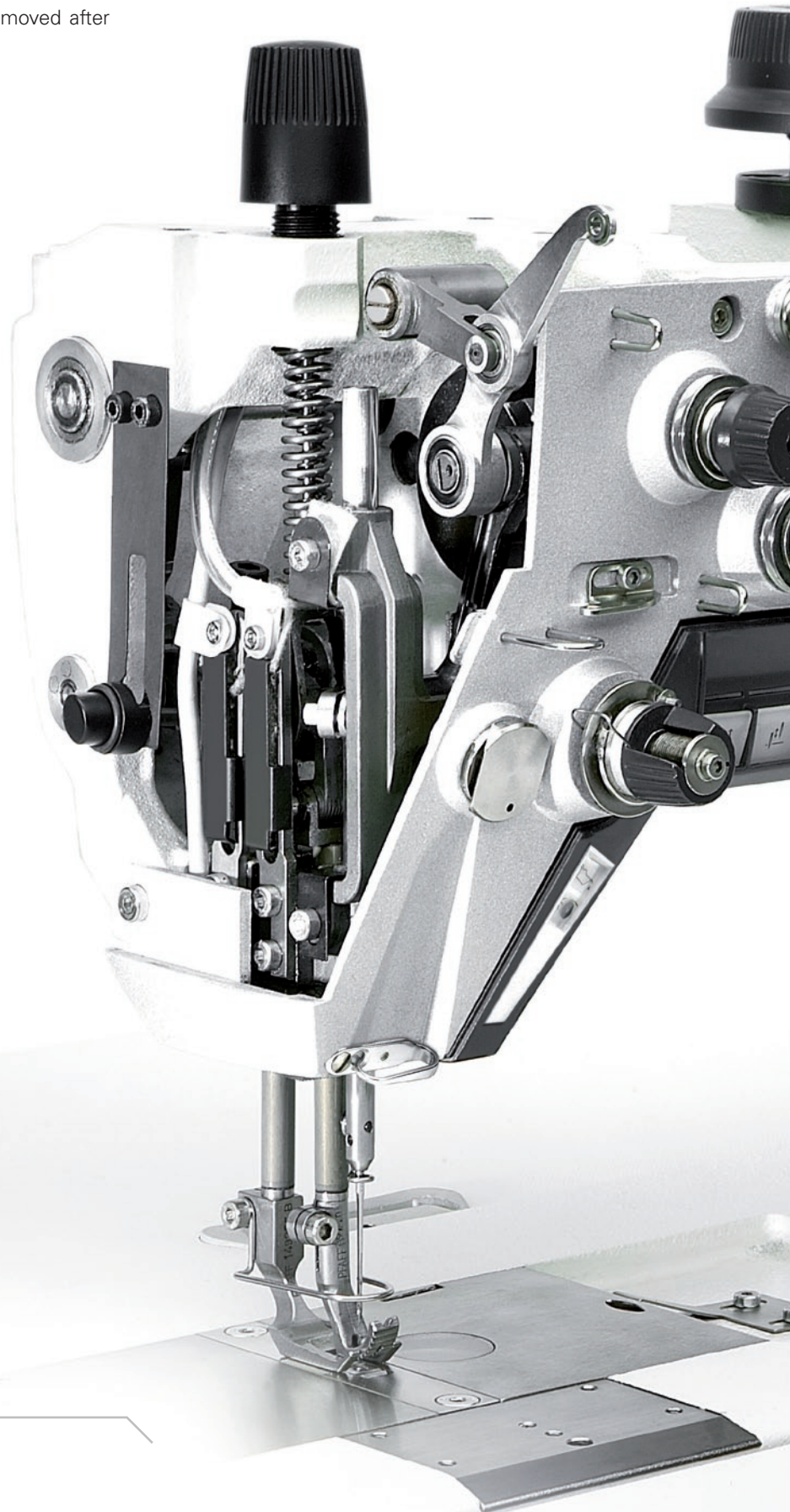

POWERline 2542/2545/2546



Parts kits 2545

Parts kit	Seam construction	Operation
-6/14 N (N = 6 mm) C medium weight material D heavy weight material		Standard parts kit for all types of sewing work, e.g.: <ul style="list-style-type: none"> • Closing seams • Edge sewing work on fitted covers • Fancy seams
-6/14 N9 (N9 = 9 mm) C medium weight material D heavy weight material		
-6/14 N12 (N12 = 12 mm) C medium weight material D heavy weight material		
-2/04 N (N = 6 mm) C medium weight material Top-stitch width: 1.5 (standard), 2, 3, 4 mm		Work on right edge e.g. <ul style="list-style-type: none"> • Attaching fastening sections • Sewing zip on one side
-3/04 N (N = 6 mm) C medium weight material Top-stitch width: 1.5 (standard), 2, 3, 4 mm		Work on left edge e.g. <ul style="list-style-type: none"> • Attaching fastening sections • Sewing zip on one side
-6/01 N (N = 6 mm) C medium weight material		Standard, feeding optimized, parts set especially for applications where seam control is of utmost importance, e.g.: <ul style="list-style-type: none"> • Closing seams • Fancy seams
-6/01 N9 (N9 = 9 mm) C medium weight material		
-6/01 C N9-900/82 (N9 = 9 mm) C medium weight material		Standard, feeding optimized, parts set especially for applications with thread trimmer for short thread ends (-900/82), e.g.: <ul style="list-style-type: none"> • Closing seams • Fancy seams (Top-stitching work)
-6/07 N (N = 6 mm) C medium weight material		Closing seams, topstitching work on edges with cross seams (Climbing parts set)
-6/07 N9 (N9 = 9 mm) C medium weight material		Closing seams, topstitching work on edges with cross seams (Climbing parts set)

	Feed dog	Needle plate	Top feeder	Presser foot
	91-159 026-04/002 (CN) 91-159 026-04/003 (DN) 	91-150 919-25 (CN6/DN6) 91-150 920-25 (CN9/DN9) 91-150 921-25 (CN12/DN12) 	91-049 394-93/003 (CN) 91-049 394-93/011 (DN) 	91-149 262-91 (CN6/DN6) 91-149 264-91 (CN9/DN9) 91-149 266-91 (CN12/DN12) 
	91-159 027-04/... * 91-159 039-04/002 (4 mm) 	91-150 935-24/... * 	91-049 394-93/... * 	91-149 268-93/... * 
	91-159 030-04/... * 91-159 039-04/002 (4 mm) 	91-150 936-24/... * 91-150 935-24/004 (4 mm) 	91-049 408-93/... * 91-049 394-93/003 (4 mm) 	91-149 270-93/... * 
	91-159 039-04/002 	91-150 935-24/004 (CN) 91-150 922-25 (CN9) 	91-049 394-93/003 	91-149 262-91 (CN) 91-149 264-91 (CN9) 
	91-159 116-05 	91-151 071-91 	91-049 394-93/003 	91-149 264-91 (CN9) 
	91-159 026-04/002 	91-150 919-25 (CN) 91-150 920-25 (CN9) 	91-049 394-93/003 	91-049 772-93/032 

* Size required!

Parts kits 2545

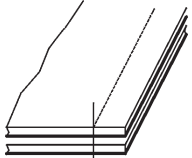
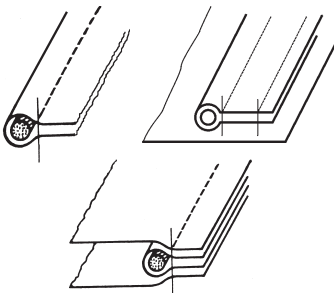
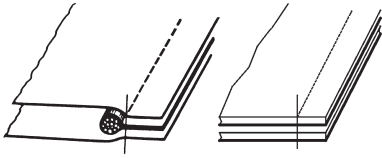
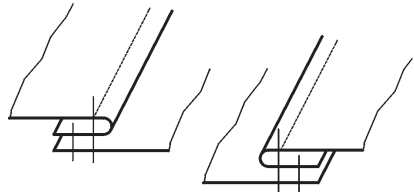
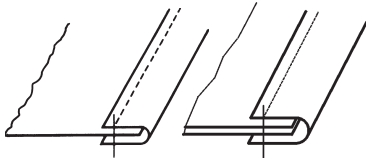
Parts kit	Seam construction	Operation
<p>-6/13 N9 (N9 = 9 mm) C medium weight material</p>		<p>Closing seams on quilted covers</p>
<p>-40/12 N9 (N9 = 9 mm) C medium weight material for piping sizes from 5 ; 6 ; 7 ; 8 ; 9 mm (standard: = 7 mm)</p>		<p>Piping work: side adjustment of feed dog for pre-piping and piping work</p>
<p>-40/14 N9 (N9 = 9 mm) C medium weight material for piping sizes from 3 ; 4 ; 5 ; 6 ; 7 ; 9 ; 11 mm (standard: = 5 + 7 mm)</p>		<p>Piping work: pre-piping and piping work</p>
<p>-113/05 N9 (N9 = 9 mm) C medium weight material Top-stitch width: 3 ; 3.5 ; 4 ; 4.5 mm (standard: = 3.5 mm) (in connection with edge guide: 91-156-765-91)</p>		<p>Top-stitching and closing Seam on one side</p>
<p>-17/01-650/03 N9 (N9 = 9 mm) (without binder) C medium weight material Binding width: 5 ; 10 ; 15 mm</p>		<p>Binding work (on customers request)</p>

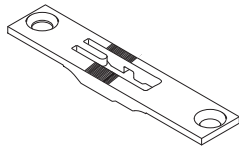
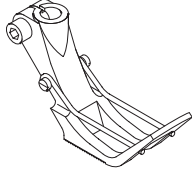
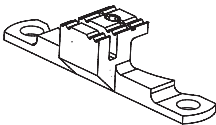
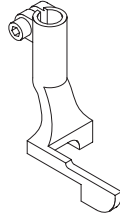
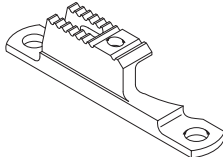
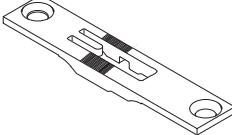
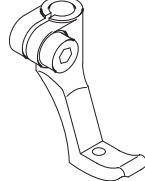
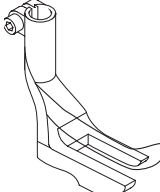
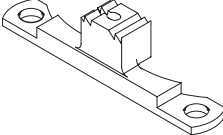
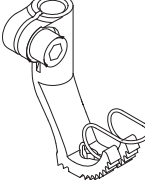
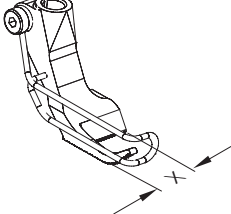
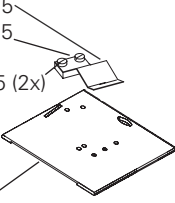

	Feed dog	Needle plate	Top feeder	Presser foot
	91-159 026-04/002 	91-150 920-25 	91-149 215-93/001 	91-149 275-91 
	91-159 038-04/001 	91-150 950-25 	91-049 402-93/... * 	91-049 782-93/... * 
	91-159 026-04/002 	91-150 920-25 	91-149 217-93/... * 	91-149 169-93/... * 
	91-159 039-04/002 	91-150 922-25 	91-149 280-93/... * 	91-149 278-93/... * (3.0 ... 3.5 mm) 91-149 282-93/... * (4.0 ... 4.5 mm) 
	91-159 050-05 	91-151 003-25 	91-049 491-93/... * 	91-149 320-93/... * 
* Size required!		other parts -17/01 91-156 796-15 91-170 363-15 11-108 174-15 (2x)  91-501 742-255	Attachment holder -17/01 91-156 269-90 	Tape holder -17/01 91-043 943-70/895 

Parts kits 2546

Parts kit	Needle gauges (– = standard)	Seam construction	Operation
-6/01 N (N = 6 mm) C medium weight material	4 ; 4.8 ; 6 ; 6.4 ; 8 ; 10 ; 12 ; 18 mm		Standard parts kit for all types of sewing work , e.g.: • Top-stitching work • Fancy seams
-6/01 N9 (N9 = 9 mm) C medium weight material	4 ; 4.8 ; 6 ; 6.4 ; 8 ; 10 ; 12 ; 16 ; 20 mm		
-6/01 N12 (N12 = 12 mm) D heavy weight material	6 ; 6.4 ; 8 ; 10 ; 12 ; 25,2 mm		
-237/10 C N9	8 up to 24 mm		Zip insertion: - Fabric edges are not turned in - Or can be turned in by hand - Or can be turned in by a guide Customer sample and a special face plate for guides required! (No. 91-502 205-70/798)
-63/24 N9 (N9 = 9 mm) C medium weight material	6 ; 8 ; 10 ; 12 ; 16 mm		Parts kit with compensating presser foot und seam-center guide for top-stiching work. (with or without tape from below)
-63/24 N12 (N12 = 12 mm) D heavy weight material	8 ; 10 ; 12, 16 mm		

Parts kits 2542

Parts kit	Needle gauges (– = standard)	Seam construction	Operation	
-6/01 A light	Stitch length: 4,5 mm (N4,5) 6,0 mm (N)		Standard parts set for general operations • Closing seams • Fancy seams	
-6/01 B medium				4.8 ; 6.4 ; 7.2mm
-6/01 C heavy				3.2 ; 4.8 ; 6.4 ; 7.2mm
	4.8 ; 6.4 ; 7.2mm			

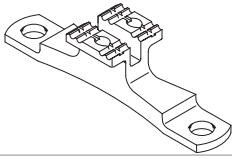
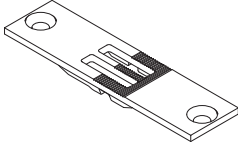
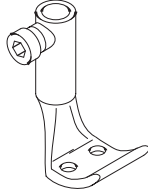
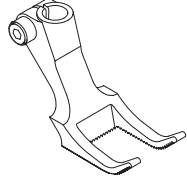
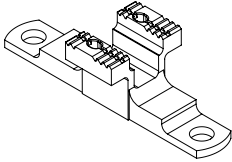
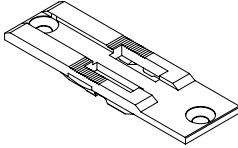
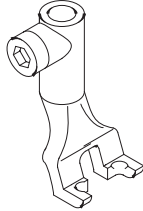
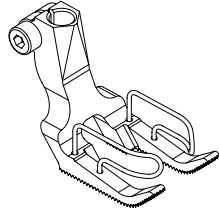
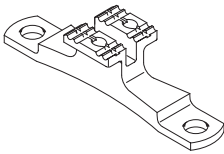
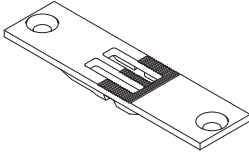
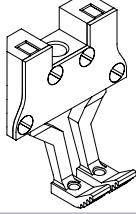
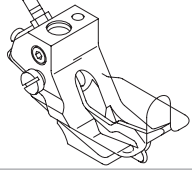
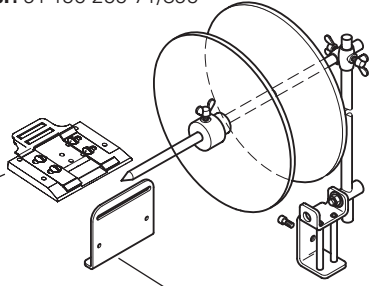
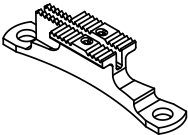
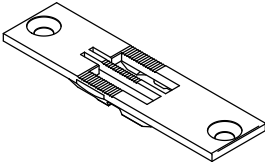
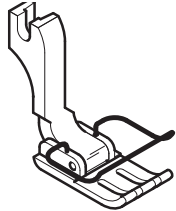
	Feed dog	Needle plate	Top feeder	Presser foot
	91-159 020-04/... (C) * 91-159 020-04/... (D) * 	91-150 943-24/... (CN) * 91-150 904-24/... (CN9) * 91-150 944-24/... (DN12) * 	91-049 385-93/... (CN/CN9) * 91-049 385-93/... (DN12) * 	91-149 283-93/... (CN) * 91-149 278-93/... (CN9) * 91-149 284-93/... (DN12) * 
	91-159 094-04/... 	91-159 028-24/... 	91-049 387-93/... 	91-149 345-93/... 
	91-159 020-04/... (C) * 91-159 020-04/... (D) * 	91-150 904-24/... (CN9) * 91-150 944-24/... (DN12) * 	91-154 978-93/... (CN/CN9) * 91-154 978-93/... (DN12) * 	91-149 370-91 bis 91-149 380-91 (CN9) * 91-149 381-91 bis 91-149 384-91 (DN12) * 
			-63/24 Tape holder: 91-156 255-71/895  Tape guide 91-501 097-21 91-044 419-25	
	Feed dog	Needle plate	Sewing foot	
	91-159 071-04/.... 	91-151 021-24/... (N4,5) 91-151 004-24/... (N) 	91-155 752-03/... (N4,5) 91-054 926-03/... (N4) 	

* Size required!

Edge guides 2545/2546





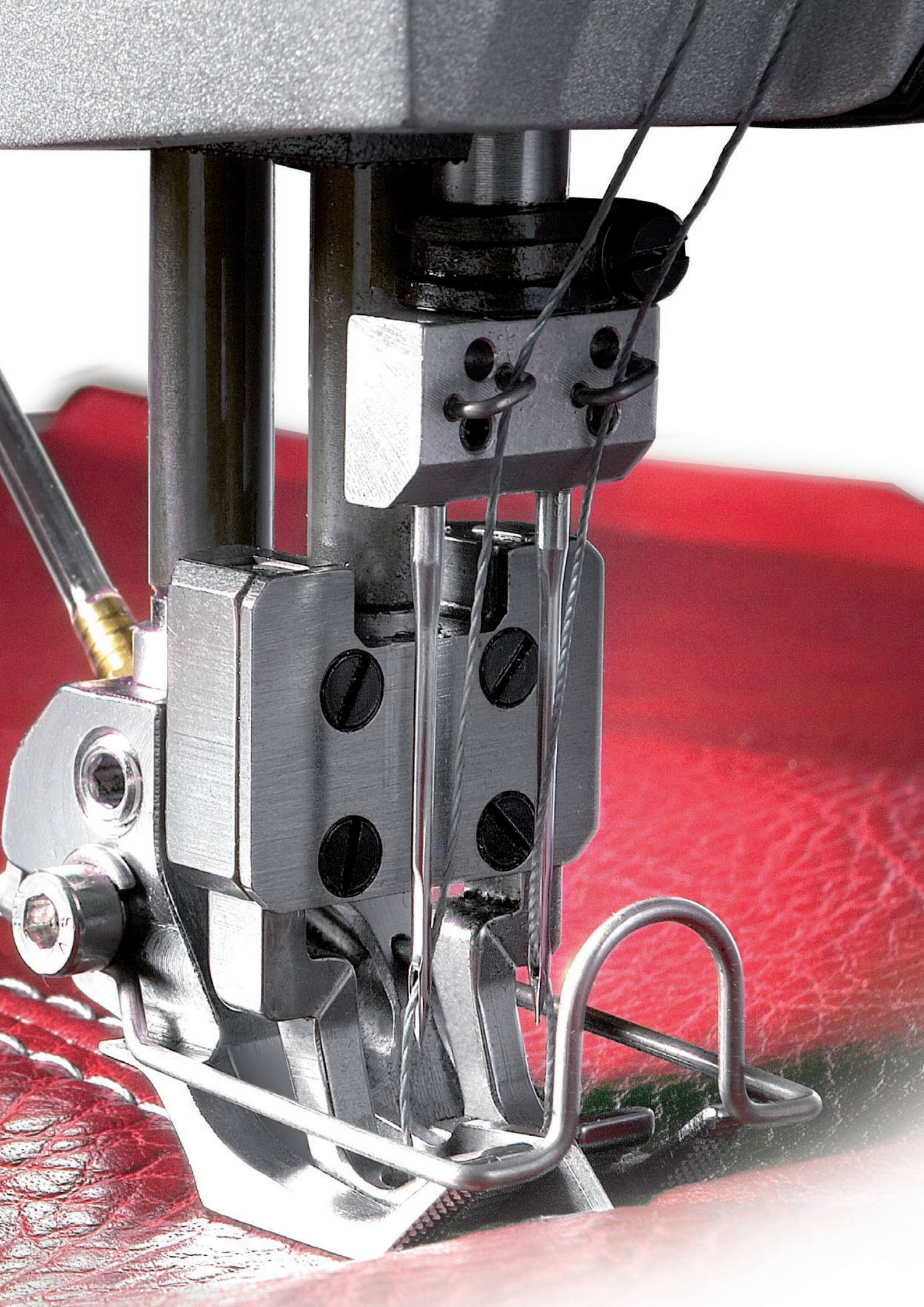

Edge guide	Parts No.	Suitable for parts kit	
		2545	2546
	91-156 763-91	-2/04 -6/07 -6/13 -6/14 -40/14	-6/01
	91-156 764-91	-3/04 -6/07 -6/13 -6/14	-6/01
	91-156 765-91	-6/07 ** -6/13 ** -6/14 ** -113/05	-6/01
	91-156 767-91	-2/04 -6/07 -6/13 -6/14 -40/14	-6/01
	91-156 768-91	-2/04 -6/07 -6/13 -6/14 -40/14	-6/01

** feet have to be adapted

POWERline 2542/2545/2546

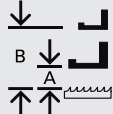

Technical data + Specifications 2545

Types		 max *	 max. mm			 - System	 - Nm	 Nm
2545 BASIC	●	3,800	12	A: 9 mm B: 20 mm		134-35	90 - 180	80/3 - 10/3
2545-G BASIC	●	3,400	12	A: 9 mm B: 20 mm		134-35	90 - 180	80/3 - 10/3
2545 CLASSIC	●	3,800	12	A: 9 mm B: 20 mm	≤ 13	134-35	90 - 180	80/3 - 10/3
2545-G CLASSIC	●	3,400	12	A: 9 mm B: 20 mm	≤ 13	134-35	90 - 180	80/3 - 10/3
2545-900/82 CLASSIC	●	3,800	9	A: 9 mm B: 20 mm	≤ 5	134-35	90 - 160	80/3 - 15/3
2545-G-900/82 CLASSIC	●	3,400	9	A: 9 mm B: 20 mm	≤ 5	134-35	90 - 160	80/3 - 15/3
2545 PLUS	●	3,800	12	A: 9 mm B: 20 mm	≤ 13	134-35	90 - 180	80/3 - 10/3
2545-900/82 PLUS	●	3,800	9	A: 9 mm B: 20 mm	≤ 5	134-35	90 - 160	80/3 - 15/3
2545-G PLUS	●	3,400	12	A: 9 mm B: 20 mm	≤ 13	134-35	90 - 180	80/3 - 10/3

* = the max. sewing speed depends on pre-selected stroke and stitch length



Number of needles



Remaining thread length after cutting in mm



Max. sewing speed



Needle system



Max. stitch length

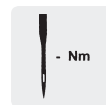

Recommended needle size in Nm

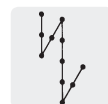

Automatic backtacking



Thread size (metrical number in Nm)

			-900/81 (82)	-909/12	-910/04	-911/35	-918/29					
C:345 x D:120	●		●						●			
C:345 x D:120		●	●						●			
C:345 x D:120	●		●	●	●	●	●					●
C:345 x D:120		●	●	●	●	●	●					●
C:345 x D:120	●		●	●	●	●	●					●
C:345 x D:120		●	●	●	●	●	●					●
C:345 x D:120	●		●	●	●	●	●	●		●		
C:345 x D:120	●		●	●	●	●	●	●		●		
C:345 x D:120		●	●	●	●	●	●	●		●		

● standard
○ option

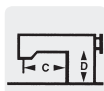

Arm clearance in mm



Needle gauge in mm



Vertical hook, large



Vertical hook, extra large



Top feed stroke (A) and fabric clearance (B)



Bottom feed, needle- and alternating unison feed



Thread trimmer

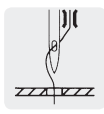

Thread nipper



Presser foot lift



Presser foot lift



Compound feed



Control for two different stitch lengths





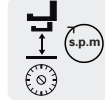



Top feed lift adjustable by knob



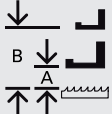
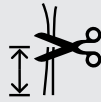







Top feed lift pre-selectable and recallable by knuckle switch, with automatic speed limitation

Technische Daten + Spezifikationen 2546

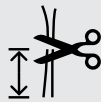
Typen								
2546 BASIC	●	3,800	12	A: 9 mm B: 20 mm		134-35	90 - 180	80/3 - 10/3
2546-G BASIC	●	3,400	12	A: 9 mm B: 20 mm		134-35	90 - 180	80/3 - 10/3
2546 PLUS	●	3,800	12	A: 9 mm B: 20 mm	≤ 13	134-35	90 - 180	80/3 - 10/3
2546-G PLUS	●	3,400	12	A: 9 mm B: 20 mm	≤ 13	134-35	90 - 180	80/3 - 10/3

Technical data + Specifications 2542

Typen								
2542 PLUS	●	3,800	6	8 mm	≤ 13	134-35	90 - 180	80/3 - 10/3

* = the max. sewing speed depends on pre-selected stroke, stitch length and needle gauge

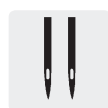

Number of needles



Remaining thread length after cutting in mm



Max. sewing speed



Needle system



Max. stitch length



















Recommended needle size in Nm

















Automatic backtacking

















Thread size (metrical number in Nm)

											
	→mm←				-900/81 (82)	-909/12	-910/04	-911/35	-918/29		
C:345 x D:120	4.0 - 50.0	●		●						●	
C:345 x D:120	4.0 - 50.0		●	●						●	
C:345 x D:120	4.0 - 50.0	●		●	●	●	●	●	●		●
C:345 x D:120	4.0 - 50.0		●	●	●	●	●	●	●		●

											
	→mm←			●	-900/81	-909/12	-910/04	-911/35	-918/26		
C:345 x D:120	4.0 - 50.0	●		●	●	●	●	●	●		

- standard
- option

	Arm clearance in mm		Bottom feed, needle- and alternating unison feed		Compound feed
	Needle gauge in mm		Thread trimmer		Control for two different stitch lengths
	Vertical hook, large		Thread nipper		Top feed lift adjustable by knob
	Vertical hook, extra large		Presser foot lift		Top feed lift pre-selectable and recallable by knuckle switch, with automatic speed limitation
	Top feed stroke (A) and fabric clearance (B)		Presser foot lift		



PFAFF Industriesysteme und Maschinen GmbH

Hans-Geiger-Str. 12 – IG Nord
D – 67661 Kaiserslautern
www.pfaff-industrial.com

Telefon: +49-6301/3205-0
Telefax: +49-6301/3205-3171
E-mail: info@pfaff-industrial.com

